



MAKE WORK  
LIFE EASIER



**INTELLIGENT**  
TORCH SOLUTIONS

ARC M SERIES - UNIVERSAL SYSTEM



# A Passion for Technology & Innovation

To produce hand tools that reach the pinnacle of performance, durability and functionality you have to be passionate about what you do.

At Arc Torchology the research and development department is the beating heart of our company.

Every single component is conceived, developed, manufactured and tested in-house.

Our development and testing activities are loaded with cutting edge technologies, many of which have been developed specifically by us to meet the very stringent demands we place on our design solutions.

These specialized, bespoke solutions allow us to develop products that surpass the prerequisite of industry standards, inventing increasingly more beneficial products that deliver maximum results for the operator.

FEATURING NEW TECHNOLOGIES



find out more [arctorchology.com](http://arctorchology.com)

**This is not business as usual.**

# Contents

	Arc M Universal System Range Overview and Ratings	2
	<b>Torch Range</b>	
<b>Industrial Air-Cooled Series Universal System</b>	M1	6
	M18	8
	M2	10
	M22	12
<b>Industrial Air-Cooled Series - Multijust Universal System</b>	M2M	14
	M22M	16
<b>High Performance Air-Cooled Series Universal System</b>	M3 <i>New</i>	18
	M4 <i>New</i>	20
	M5	22
	M6	24
<b>Universal System</b>	Universal System Kits	26
	<b>Wear Parts</b>	
	Industrial Series	29
	High Performance Series	32

# AIR-COOLED

## Arc M Industrial Mig Series



MAKE WORK  
LIFE EASIER

### TECHNICAL SPECIFICATIONS

IEC/EN 60974-7

#### M1

Cooling Method	Air-Cooled	
Rating:	CO <sub>2</sub>	180A
	Mixed Gas M21	150A
Duty Cycle	60%	
Wire Size	0.6-1.0mm	



#### M18

Cooling Method	Air-Cooled	
Rating:	CO <sub>2</sub>	210A
	Mixed Gas M21	180A
Duty Cycle	60%	
Wire Size	0.6-1.0mm	



#### M2

Cooling Method	Air-Cooled	
Rating:	CO <sub>2</sub>	230A
	Mixed Gas M21	200A
	Pulse	110A
Duty Cycle	60%	
Wire Size	0.8-1.2mm	



M2 Video

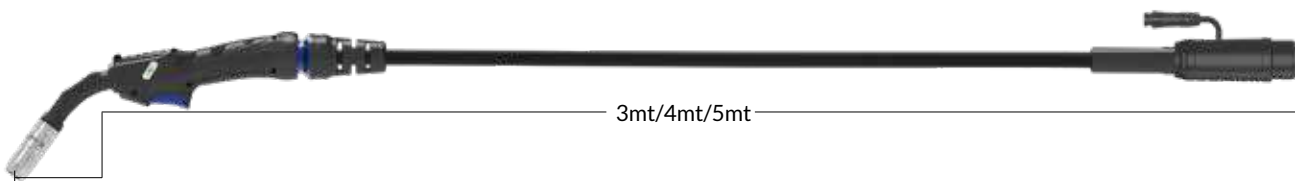

#### M22

Cooling Method	Air-Cooled	
Rating:	CO <sub>2</sub>	250A
	Mixed Gas M21	220A
	Pulse	120A
Duty Cycle	60%	
Wire Size	0.8-1.2mm	

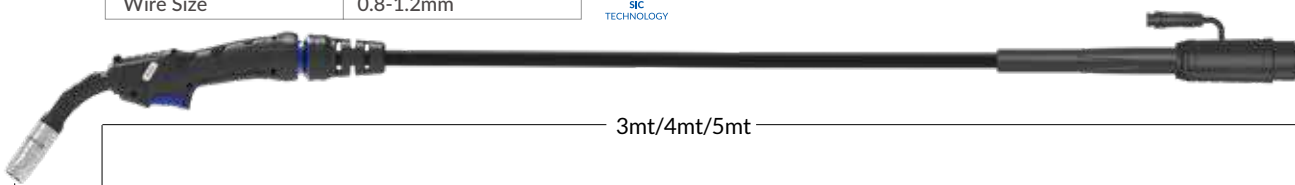

# AIR-COOLED

## Arc M Industrial Mig Series - Multitjust



MAKE WORK  
LIFE EASIER

### M2M

Cooling Method	Air-Cooled	
Rating:	CO <sub>2</sub>	230A
	Mixed Gas M21	200A
	Pulse	110A
Duty Cycle	60%	
Wire Size	0.8-1.2mm	

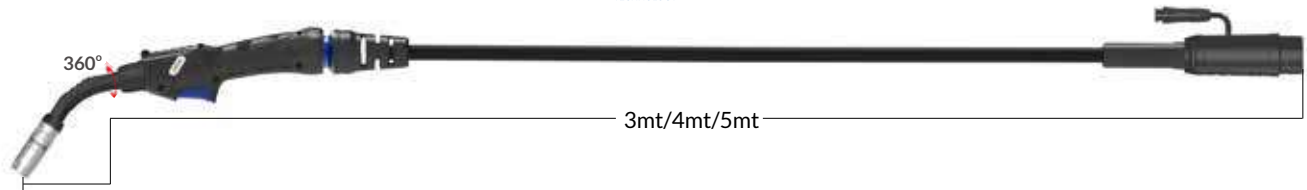

### M22M

Cooling Method	Air-Cooled	
Rating:	CO <sub>2</sub>	250A
	Mixed Gas M21	220A
	Pulse	120A
Duty Cycle	60%	
Wire Size	0.8-1.2mm	

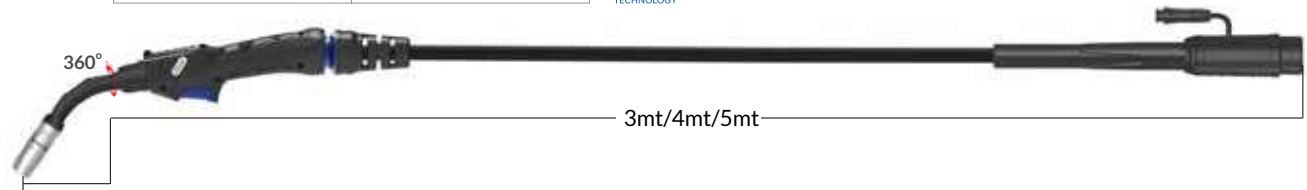

# AIR-COOLED

## Arc M High Performance Mig Series



MAKE WORK  
LIFE EASIER

### M3

Cooling Method	Air-Cooled	Max. Load
	CO <sub>2</sub>	300A 10.5KW
Rating: Mixed Gas M21	270A	8.9KW
Duty Cycle	60%	
Wire Size	0.9-1.2mm	

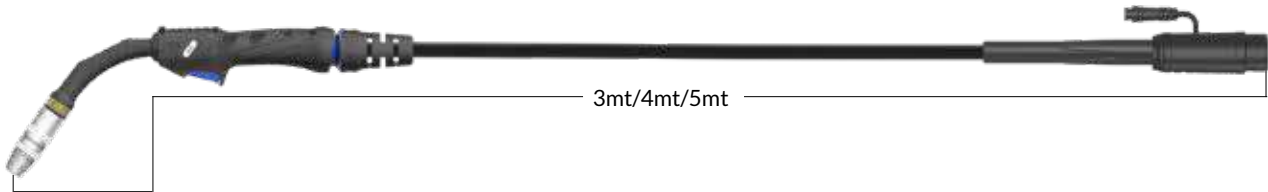

### M4

Cooling Method	Air-Cooled	Max. Load
	CO <sub>2</sub>	350A 14.1KW
Rating: Mixed Gas M21	320A	11.4KW
Duty Cycle	60%	
Wire Size	0.9-1.2mm	



# AIR-COOLED

## Arc M High Performance Mig Series



MAKE WORK  
LIFE EASIER

### M5

Cooling Method	Air-Cooled	Max. Load
Rating: CO <sub>2</sub>	390A	14.6KW
	Mixed Gas M21	360A
Duty Cycle	60%	
Wire Size	0.9-1.6mm	



M5 Video

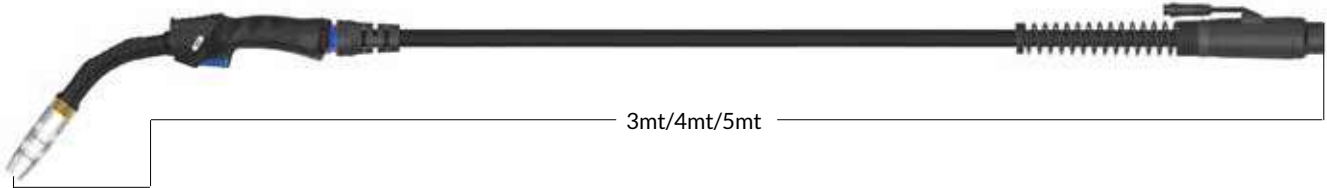

### M6

Cooling Method	Air-Cooled	Max. Load
Rating: CO <sub>2</sub>	430A	17.6KW
	Mixed Gas M21	400A
Duty Cycle	60%	
Wire Size	0.9-2.0mm	

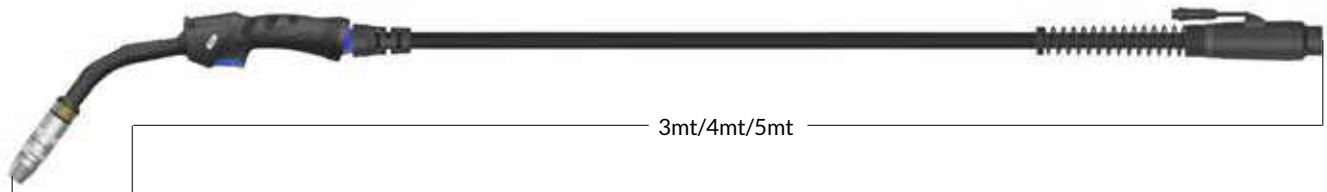

# M1 Air-Cooled Mig Welding Torch

Ratings:	180A CO <sub>2</sub> , 150A mixed gas M21, EN60974-7 @ 60% duty cycle. 0.6mm-1.0mm wires
----------	---

Tackles everyday jobs effortlessly.

## ARC M INDUSTRIAL MIG TORCH PACKAGES

M1 Torches are supplied with a Universal termination as standard and are supplied 'ready to weld' with all wear parts fitted.



## Wear Parts

### A Nozzles

Part Number	Description	Bore	Wall	Material
•AM1CN	Conical Nozzle Assembly	12mm	1.0mm	Copper
AM1TN	Tapered Nozzle Assembly	10.6mm	1.0mm	Copper

### B Contact Tips

Part Number	Description	Size (mm)	Wire Size (mm-inch)	Material
AM1CT06	Contact Tip	M6*25.0	0.6 - 0.023"	Copper
•AM1CT08	Contact Tip	M6*25.0	0.8 - 0.030"	Copper
AM1CT09	Contact Tip	M6*25.0	0.9 - 0.035"	Copper
AM1CT10	Contact Tip	M6*25.0	1.0 - 0.040"	Copper
AM1CT12	Contact Tip	M6*25.0	1.2 - 0.045"	Copper
AM1CT08A	Contact Tip	M6*25.0	0.8 - 0.030"	Copper
AM1CT10A	Contact Tip	M6*25.0	1.0 - 0.040"	Copper
AM1CT12A	Contact Tip	M6*25.0	1.2 - 0.045"	Copper

### C Tip Adaptors

Part Number	Description	Material
•AM1TA	Tip Adaptor	Brass

•Denotes torch package standard wear part set-up

### D Liners

Part Number	Description	Wire Size
•AM1535-30	Steel Liner x 3mt	0.6-0.9mm
•AM1535-40	Steel Liner x 4mt	0.6-0.9mm
•AM1535-50	Steel Liner x 5mt	0.6-0.9mm

For alternate liner options please refer to page 31



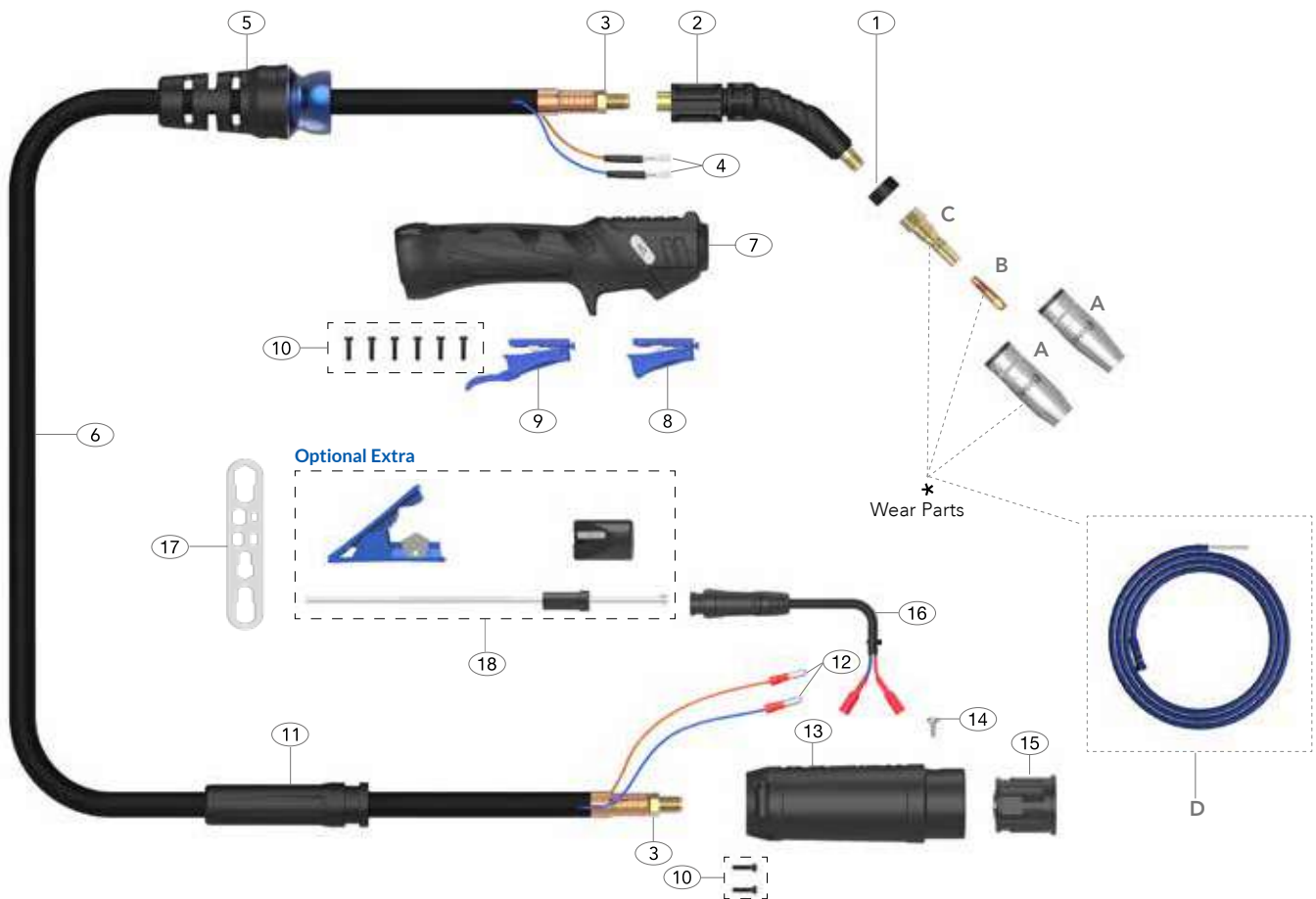

## Spare Parts

Part Number	Description
1 AM1AP	Neck Insulator
2 AM1001	Swan Neck Assembly
3 AM1505	Lock Nut
4 AM1521	Cable Terminal
5 AM1514	Handle Cable Support c/w Ball Joint
6 AM1517-30	Ultraflex Cable Assembly x 3mt
AM1517-40	Ultraflex Cable Assembly x 4mt
AM1517-50	Ultraflex Cable Assembly x 5mt
7 AM2514	Handle Kit
8 AM2516	Microswitch Standard Trigger
9 AM2516L	Microswitch Extended Trigger
10 AMSP1-1	Screw Pack
11 AM2841	Cable Support
12 AM1522	Cable Terminal Male
13 AM2578H/S	Gun Plug Housing
14 AML1541	Gun Plug Screw
15 AM-ECEM1528-2	Hybrid Plug body
16 AMQF-SW	Male Switch Wire Plug

Part Number	Description
17 AMWS	Wear Parts Spanner
<b>Optional Extra</b>	
18 AMCLST-KITS	Combi-Liner Set-up kit-Optional

### Welding with Soft Wires

For welding with Aluminum wires use a Combi-liner (page 31). Optimum installation is achieved when using the Combi-liner set-up kit.

# M18 Air-Cooled Mig Welding Torch

Ratings:	210A CO <sub>2</sub> , 180A mixed gas M21, EN60974-7 @ 60% duty cycle. 0.6mm-1.0mm wires
----------	---

Ideal for 0.8mm hard wires and semi-industrial environments.

## ARC M INDUSTRIAL MIG TORCH PACKAGES

M18 Torches are supplied with a Universal termination as standard and are supplied 'ready to weld' with all wear parts fitted.



## Wear Parts

### A Nozzles

Part Number	Description	Bore	Wall	Material
•AM18CN	Conical Nozzle Assembly	14mm	1.5mm	Copper
AM18TN	Tapered Nozzle Assembly	12mm	1.5mm	Copper

### B Contact Tips

Part Number	Description	Size (mm)	Wire Size (mm-inch)	Material
AM1CT06	Contact Tip	M6*25.0	0.6 - 0.023"	Copper
•AM1CT08	Contact Tip	M6*25.0	0.8 - 0.030"	Copper
AM1CT09	Contact Tip	M6*25.0	0.9 - 0.035"	Copper
AM1CT10	Contact Tip	M6*25.0	1.0 - 0.040"	Copper
AM1CT12	Contact Tip	M6*25.0	1.2 - 0.045"	Copper
AM1CT08A	Contact Tip	M6*25.0	0.8 - 0.030"	Copper
AM1CT10A	Contact Tip	M6*25.0	1.0 - 0.040"	Copper
AM1CT12A	Contact Tip	M6*25.0	1.2 - 0.045"	Copper

### C Tip Adaptors

Part Number	Description	Material
•AM18TA	Tip Adaptor	Brass

•Denotes torch package standard wear part set-up

### D Liners

Part Number	Description	Wire Size
•AM1535-30	Steel Liner x 3mt	0.6-0.9mm
•AM1535-40	Steel Liner x 4mt	0.6-0.9mm
•AM1535-50	Steel Liner x 5mt	0.6-0.9mm

For alternate liner options please refer to page 31

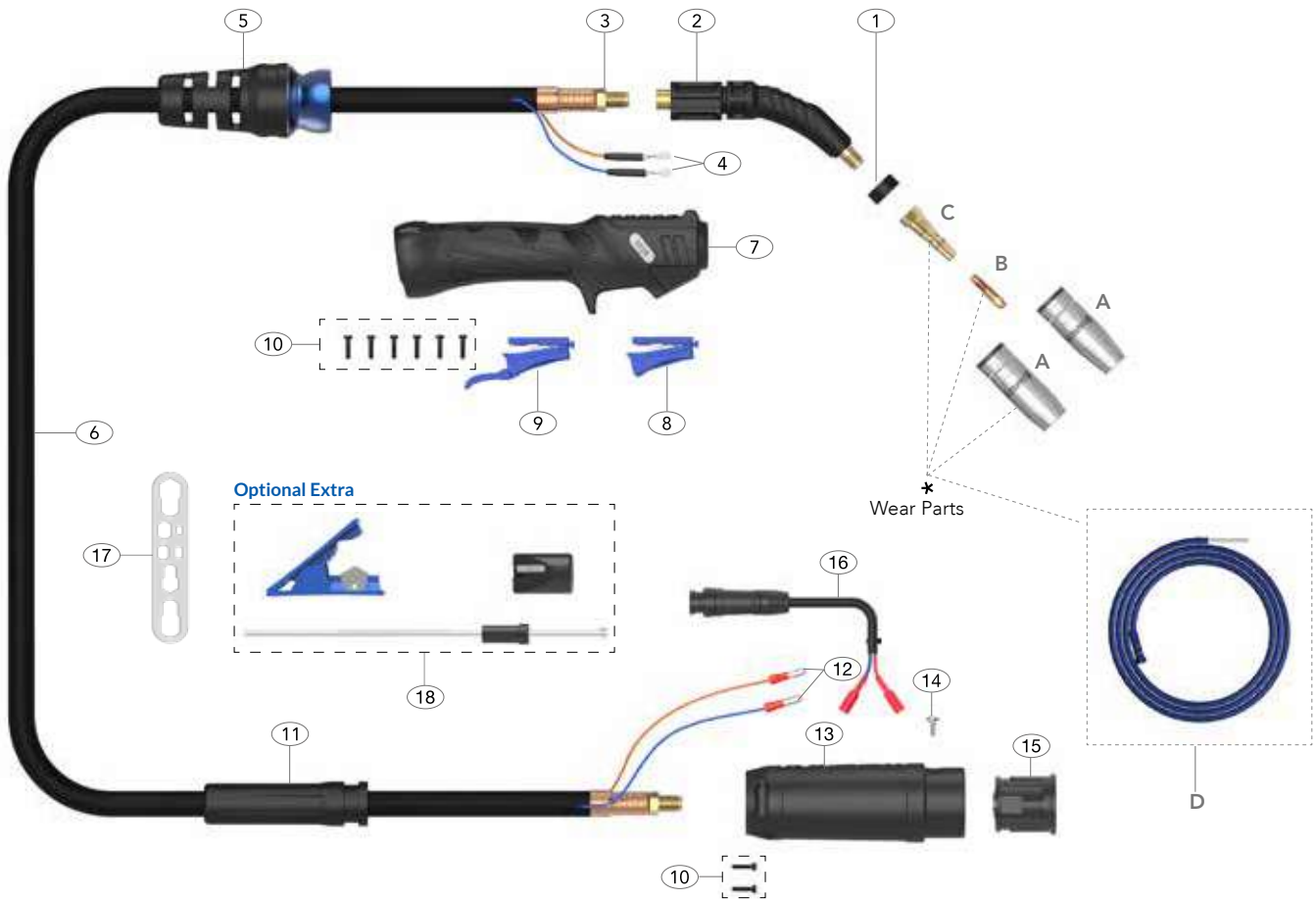

## Spare Parts

Part Number	Description
1 AM18AP	Neck Insulator
2 AM18001	Swan Neck Assembly
3 AM1505	Lock Nut
4 AM1521	Cable Terminal
5 AM1514	Handle Cable Support c/w Ball Joint
6 AM1517-30	Ultraflex Cable Assembly x 3mt
AM1517-40	Ultraflex Cable Assembly x 4mt
AM1517-50	Ultraflex Cable Assembly x 5mt
7 AM2514	Handle Kit
8 AM2516	Microswitch Standard Trigger
9 AM2516L	Microswitch Extended Trigger
10 AMSP1-1	Screw Pack
11 AM2841	Cable Support
12 AM1522	Cable Terminal Male
13 AM2578H/S	Gun Plug Housing
14 AML1541	Gun Plug Screw
15 AM-ECEM1528-2	Hybrid Plug body
16 AMQF-SW	Male Switch Wire Plug

Part Number	Description
17 AMWS	Wear Parts Spanner
<b>Optional Extra</b>	
18 AMCLST-KITS	Combi-Liner Set-up kit-Optional

### Welding with Soft Wires

For welding with Aluminum wires use a Combi-liner (page 31). Optimum installation is achieved when using the Combi-liner set-up kit.

# M2 Air-Cooled Mig Welding Torch

Ratings:	230A CO <sub>2</sub> , 200A mixed gas M21, 110A pulse. EN60974-7 @ 60% duty cycle. 0.8mm-1.2mm wires
----------	---

Ideal for 0.8-1.0mm hard wires and industrial environments.



M2 Video

## ARC M INDUSTRIAL MIG TORCH PACKAGES

M2 Torches are supplied with a Universal termination as standard and are supplied 'ready to weld' with all wear parts fitted.



## Wear Parts

### A Nozzles

Part Number	Description	Bore	Wall	Material
•AM2CN	Conical Nozzle Assembly	15mm	1.9mm	Copper
AM2TN	Tapered Nozzle Assembly	12mm	1.9mm	Copper

### B Contact Tips

Part Number	Description	Size (mm)	Wire Size (mm-inch)	Material
AM2CT08	Contact Tip	M8*29.5	0.8 - 0.030"	Copper
AM2CT09	Contact Tip	M8*29.5	0.9 - 0.035"	Copper
•AM2CT10	Contact Tip	M8*29.5	1.0 - 0.040"	Copper
AM2CT12	Contact Tip	M8*29.5	1.2 - 0.045"	Copper
AM2CT08A	Contact Tip	M8*29.5	0.8 - 0.030"	Copper
AM2CT10A	Contact Tip	M8*29.5	1.0 - 0.040"	Copper
AM2CT12A	Contact Tip	M8*29.5	1.2 - 0.045"	Copper

### C Tip Adaptors

Part Number	Description	Material
•AM2TA	Tip Adaptor	Brass

•Denotes torch package standard wear part set-up

### D Liners

Part Number	Description	Wire Size
•AM2524-30	Steel Liner x 3mt	1.0-1.2mm
•AM2524-40	Steel Liner x 4mt	1.0-1.2mm
•AM2524-50	Steel Liner x 5mt	1.0-1.2mm

For alternate liner options please refer to page 31

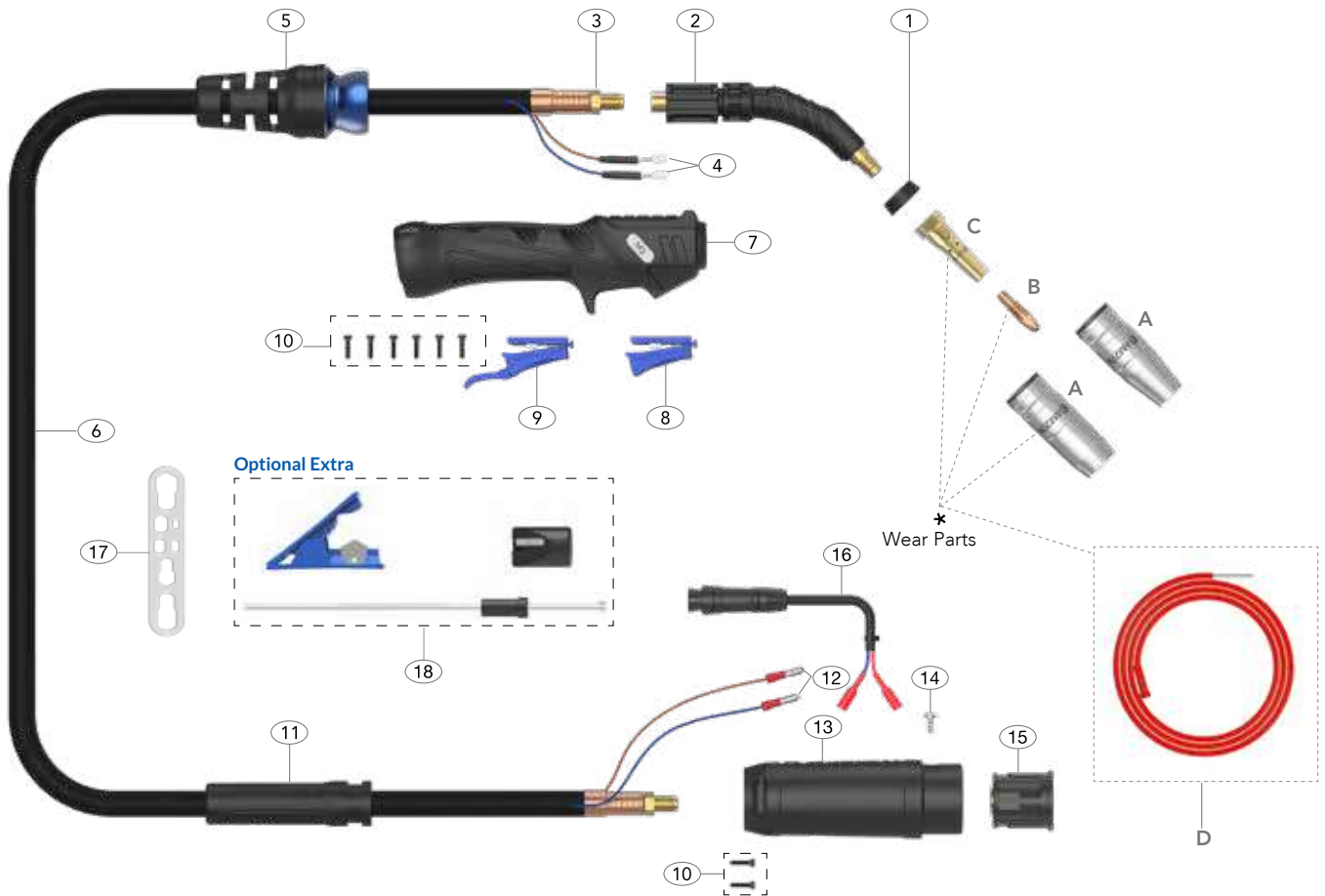

**Spare Parts**

Part Number	Description
1 AM2AP	Neck Insulator
2 AM2001	Swan Neck Assembly
3 AM1505	Lock Nut
4 AM1521	Cable Terminal
5 AM1514	Handle Cable Support c/w Ball Joint
6 AM2503-30	Ultraflex Cable Assembly x 3mt
AM2503-40	Ultraflex Cable Assembly x 4mt
AM2503-50	Ultraflex Cable Assembly x 5mt
7 AM2514	Handle Kit
8 AM2516	Microswitch Standard Trigger
9 AM2516L	Microswitch Extended Trigger
10 AMSP1-1	Screw Pack
11 AM2841	Cable Support
12 AM1522	Cable Terminal Male
13 AM2578H/S	Gun Plug Housing
14 AML1541	Gun Plug Screw
15 AM-ECEM1528-2	Hybrid Plug body
16 AMQF-SW	Male Switch Wire Plug

Part Number	Description
17 AMWS	Wear Parts Spanner
<b>Optional Extra</b>	
18 AMCLST-KITS	Combi-Liner Set-up kit-Optional

**Welding with Soft Wires**

For welding with Aluminum wires use a Combi-liner (page 31). Optimum installation is achieved when using the Combi-liner set-up kit.

# M22 Air-Cooled Mig Welding Torch

Ratings:	250A CO <sub>2</sub> , 220A mixed gas M21, 120A pulse. EN60974-7 @ 60% duty cycle. 0.8mm-1.2mm wires
----------	---

A great all-round Industrial torch for high duty 200 Amp solid wires and low duty Pulse Mig Aluminium applications.

## ARC M INDUSTRIAL MIG TORCH PACKAGES

M22 Torches are supplied with a Universal termination as standard and are supplied 'ready to weld' with all wear parts fitted.

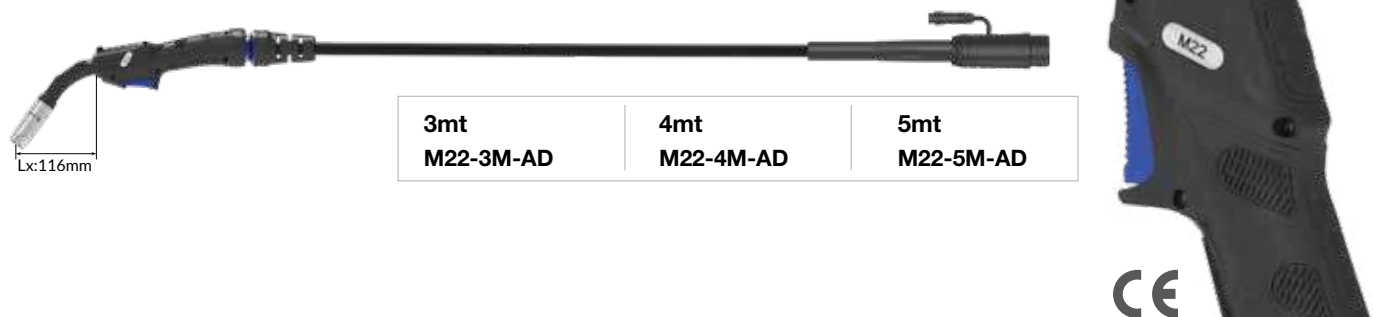

## Wear Parts

### A Nozzles

Part Number	Description	Bore	Wall	Material
•AM22CN	Conical Nozzle Assembly	16mm	1.75mm	Copper
AM22CNHD	Conical Nozzle HD Assembly	16mm	2.00mm	Copper
AM22TN	Tapered Nozzle Assembly	14mm	1.75mm	Copper

### D Liners

Part Number	Description	Wire Size
•AM2524-30	Steel Liner x 3mt	1.0-1.2mm
•AM2524-40	Steel Liner x 4mt	1.0-1.2mm
•AM2524-50	Steel Liner x 5mt	1.0-1.2mm

For alternate liner options please refer to page 31

### B Contact Tips

Part Number	Description	Size (mm)	Wire Size (mm-inch)	Material
AM2CT08	Contact Tip	M8*29.5	0.8 - 0.030"	Copper
AM2CT09	Contact Tip	M8*29.5	0.9 - 0.035"	Copper
•AM2CT10	Contact Tip	M8*29.5	1.0 - 0.040"	Copper
AM2CT12	Contact Tip	M8*29.5	1.2 - 0.045"	Copper
AM2CT08A	Contact Tip	M8*29.5	0.8 - 0.030"	Copper
AM2CT10A	Contact Tip	M8*29.5	1.0 - 0.040"	Copper
AM2CT12A	Contact Tip	M8*29.5	1.2 - 0.045"	Copper

### Arc Conical HD Nozzle

Ideal for High Amperage and Pulse Welding

### C Tip Adaptors

Part Number	Description	Material
•AM22TA	Tip Adaptor	Brass

•Denotes torch package standard wear part set-up

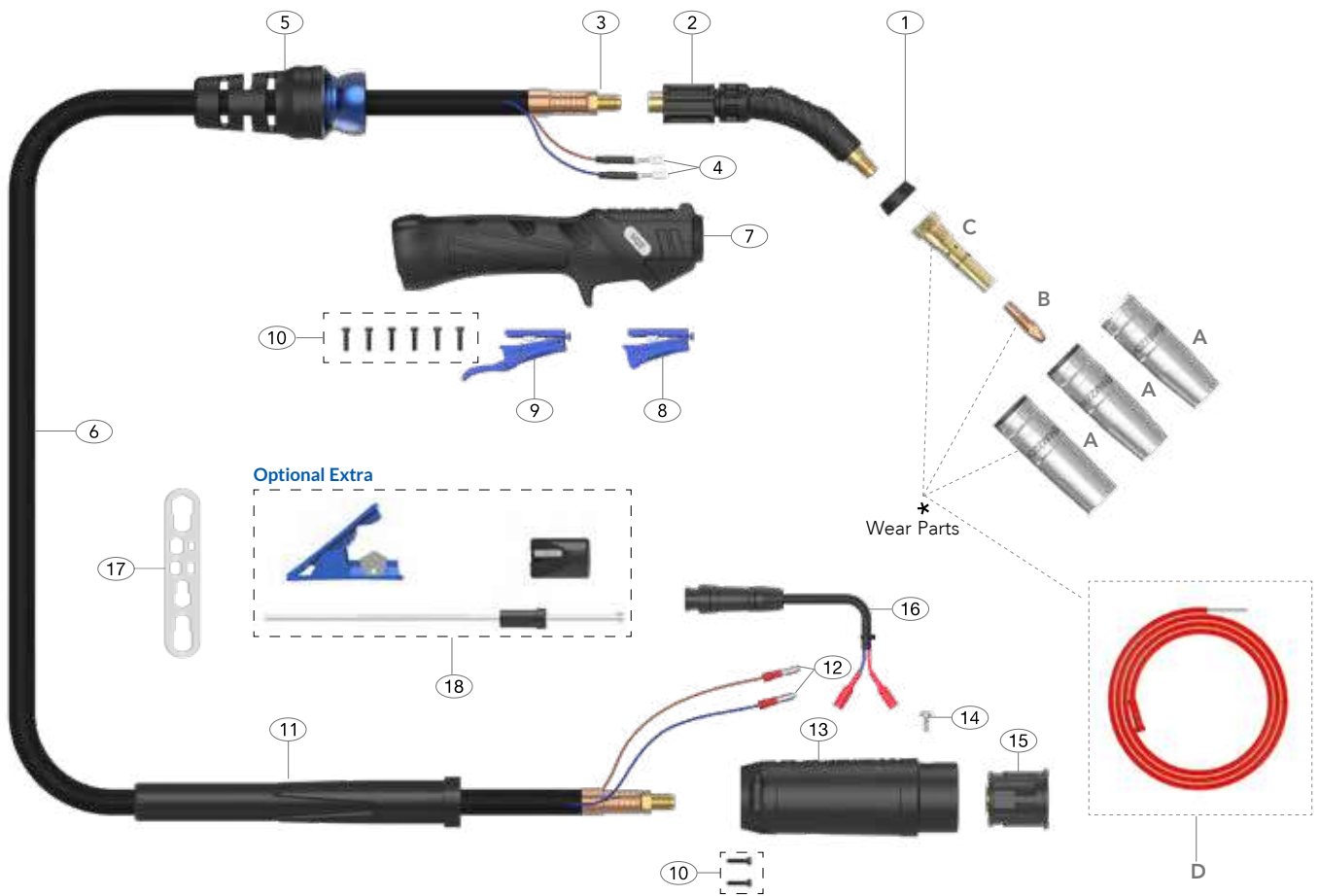

## Spare Parts

Part Number	Description
1 AM2AP	Neck Insulator
2 AM22001	Swan Neck Assembly
3 AM1505	Lock Nut
4 AM1521	Cable Terminal
5 AM1514	Handle Cable Support c/w Ball Joint
6 AM2603-30	Ultraflex Cable Assembly x 3mt
AM2603-40	Ultraflex Cable Assembly x 4mt
AM2603-50	Ultraflex Cable Assembly x 5mt
7 AM2514	Handle Kit
8 AM2516	Microswitch Standard Trigger
9 AM2516L	Microswitch Extended Trigger
10 AMSP1-1	Screw Pack
11 AMPA3541	Cable Support
12 AM1522	Cable Terminal Male
13 AM2578H/L	Gun Plug Housing
14 AML1541	Gun Plug Screw
15 AM-ECEM1528-2	Hybrid Plug body
16 AMQF-SW	Male Switch Wire Plug

Part Number	Description
17 AMWS	Wear Parts Spanner
<b>Optional Extra</b>	
18 AMCLST-KITS	Combi-Liner Set-up kit-Optional

### Welding with Soft Wires

For welding with Aluminum wires use a Combi-liner (page 31). Optimum installation is achieved when using the Combi-liner set-up kit.

# M2M Air-Cooled Mig Welding Torch - Multijust

Ratings:	230A CO <sub>2</sub> , 200A mixed gas M21, 110A pulse. EN60974-7 @ 60% duty cycle. 0.8mm-1.2mm wires
----------	---

Ideal for 0.8-1.0mm hard wires and industrial environments.  
Fitted with a longer neck with 360° rotation, perfect for multiple positions in difficult to reach areas.

## ARC M INDUSTRIAL MIG TORCH PACKAGES - MULTIJUST

M2M Multijust Torches are supplied with a Universal termination as standard and are supplied 'ready to weld' with all wear parts fitted.



<b>3mt</b> <b>M2M-3M-AD</b>	<b>4mt</b> <b>M2M-4M-AD</b>	<b>5mt</b> <b>M2M-5M-AD</b>
--------------------------------	--------------------------------	--------------------------------



### Wear Parts

#### A Nozzles

Part Number	Description	Bore	Wall	Material
•AM2CN	Conical Nozzle Assembly	15mm	1.9mm	Copper
AM2TN	Tapered Nozzle Assembly	12mm	1.9mm	Copper

#### B Contact Tips

Part Number	Description	Size (mm)	Wire Size (mm-inch)	Material
AM2CT08	Contact Tip	M8*29.5	0.8 - 0.030"	Copper
AM2CT09	Contact Tip	M8*29.5	0.9 - 0.035"	Copper
•AM2CT10	Contact Tip	M8*29.5	1.0 - 0.040"	Copper
AM2CT12	Contact Tip	M8*29.5	1.2 - 0.045"	Copper
AM2CT08A	Contact Tip	M8*29.5	0.8 - 0.030"	Copper
AM2CT10A	Contact Tip	M8*29.5	1.0 - 0.040"	Copper
AM2CT12A	Contact Tip	M8*29.5	1.2 - 0.045"	Copper

#### C Tip Adaptors

Part Number	Description	Material
•AM2TA	Tip Adaptor	Brass

•Denotes torch package standard wear part set-up

#### D Liners

Part Number	Description	Wire Size
•AM2524-30	Steel Liner x 3mt	1.0-1.2mm
•AM2524-40	Steel Liner x 4mt	1.0-1.2mm
•AM2524-50	Steel Liner x 5mt	1.0-1.2mm

For alternate liner options please refer to page 31



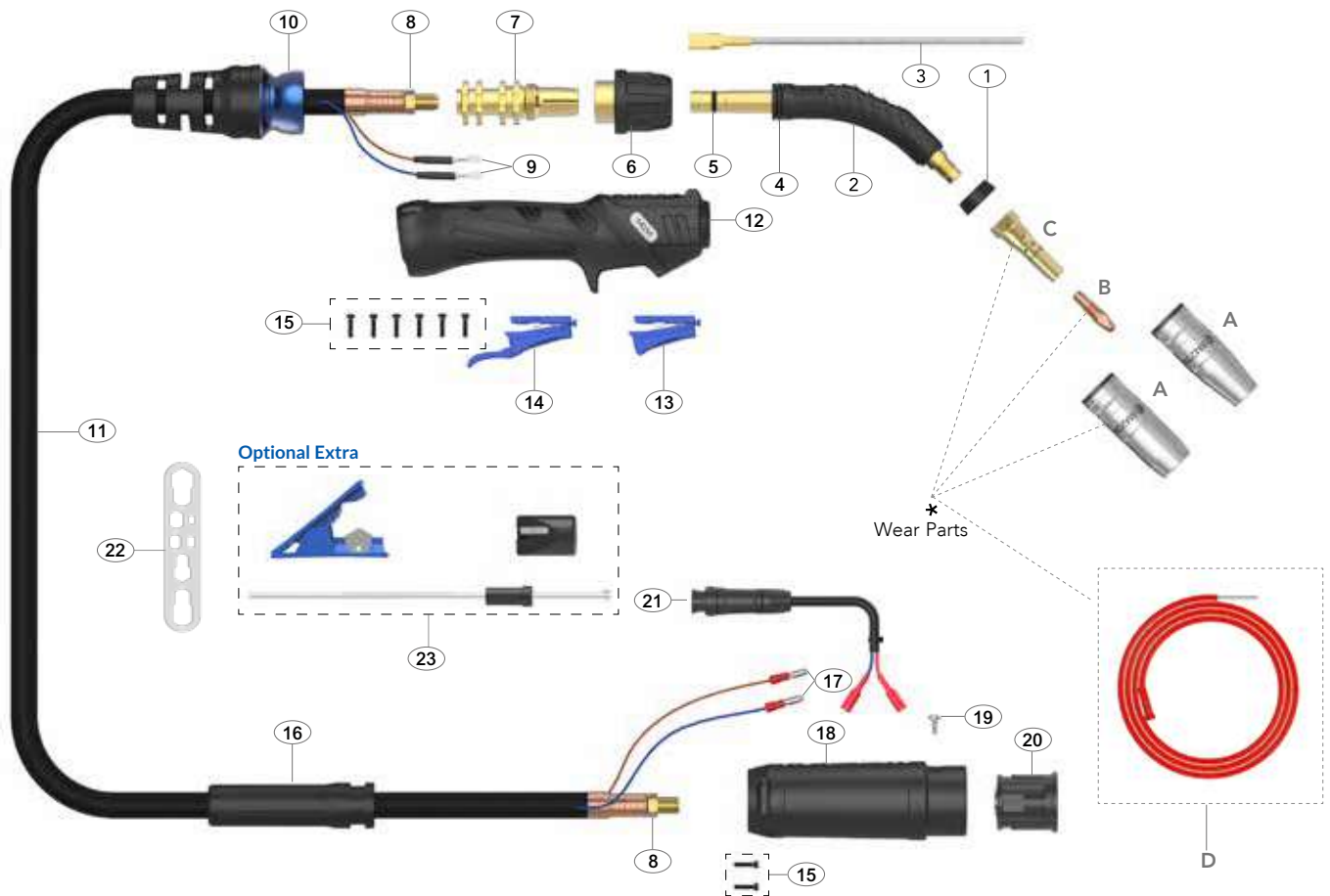

## Spare Parts

Part Number	Description
1 AM2AP	Neck Insulator
2 AM2001M	Swan Neck Assembly - Multijust
3 AM2MJL	Neck Jump Liner 0.8-1.2mm - Hard Wire
4 AM-MJ1509	Neck 'O' Ring(Ø14xØ2.5)
5 AM-MJ1508	Neck 'O' Ring(Ø8.5xØ1.5)
6 AM1516M	Neck Nut - Multijust
7 AM1515M	Socket Connection
8 AM1505	Lock Nut
9 AM1521	Cable Terminal
10 AM1514	Handle Cable Support c/w Ball Joint
11 AM2503-30	Ultraflex Cable Assembly x 3mt
AM2503-40	Ultraflex Cable Assembly x 4mt
AM2503-50	Ultraflex Cable Assembly x 5mt
12 AM2514	Handle Kit
13 AM2516	Microswitch Standard Trigger
14 AM2516L	Microswitch Extended Trigger
15 AMSP1-1	Screw Pack
16 AM2841	Cable Support
17 AM1522	Cable Terminal Male
18 AM2578H/S	Gun Plug Housing
19 AML1541	Gun Plug Screw
20 AM-ECCEM1528-2	Hybrid Plug body
21 AMQF-SW	Male Switch Wire Plug

Part Number	Description
22 AMWS	Wear Parts Spanner
<b>Optional Extra</b>	
23 AMCLST-KITS	Combi-Liner Set-up kit-Optional

### Welding with Soft Wires

For welding with Aluminum wires use a Combi-liner (page 31). Optimum installation is achieved when using the Combi-liner set-up kit.

# M22M Air-Cooled Mig Welding Torch - Multijust

Ratings:	250A CO <sub>2</sub> , 220A mixed gas M21, 120A pulse. EN60974-7 @ 60% duty cycle. 0.8mm-1.2mm wires
----------	---

A great all-round Industrial torch for high duty 200 Amp solid wires and low duty Pulse Mig Aluminium applications.  
Fitted with a longer neck with 360° rotation, perfect for multiple positions in difficult to reach areas.



## ARC M INDUSTRIAL MIG TORCH PACKAGES - MULTIJUST

M22M Multijust Torches are supplied with a Universal termination as standard and are supplied 'ready to weld' with all wear parts fitted.

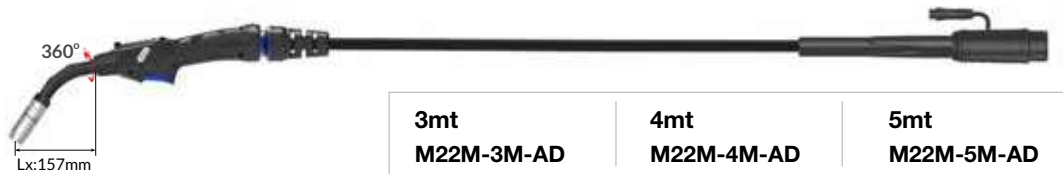

## Wear Parts

### A Nozzles

Part Number	Description	Bore	Wall	Material
•AM22CN	Conical Nozzle Assembly	16mm	1.75mm	Copper
AM22CNHD	Conical Nozzle HD Assembly	16mm	2.00mm	Copper
AM22TN	Tapered Nozzle Assembly	14mm	1.75mm	Copper

### D Liners

Part Number	Description	Wire Size
•AM2524-30	Steel Liner x 3mt	1.0-1.2mm
•AM2524-40	Steel Liner x 4mt	1.0-1.2mm
•AM2524-50	Steel Liner x 5mt	1.0-1.2mm

For alternate liner options please refer to page 31

### B Contact Tips

Part Number	Description	Size (mm)	Wire Size (mm-inch)	Material
AM2CT08	Contact Tip	M8*29.5	0.8 - 0.030"	Copper
AM2CT09	Contact Tip	M8*29.5	0.9 - 0.035"	Copper
•AM2CT10	Contact Tip	M8*29.5	1.0 - 0.040"	Copper
AM2CT12	Contact Tip	M8*29.5	1.2 - 0.045"	Copper
AM2CT08A	Contact Tip	M8*29.5	0.8 - 0.030"	Copper
AM2CT10A	Contact Tip	M8*29.5	1.0 - 0.040"	Copper
AM2CT12A	Contact Tip	M8*29.5	1.2 - 0.045"	Copper

### C Tip Adaptors

Part Number	Description	Material
•AM22TA	Tip Adaptor	Brass

•Denotes torch package standard wear part set-up

### Arc Conical HD Nozzle

Recommended for High Amperage and Pulse Welding

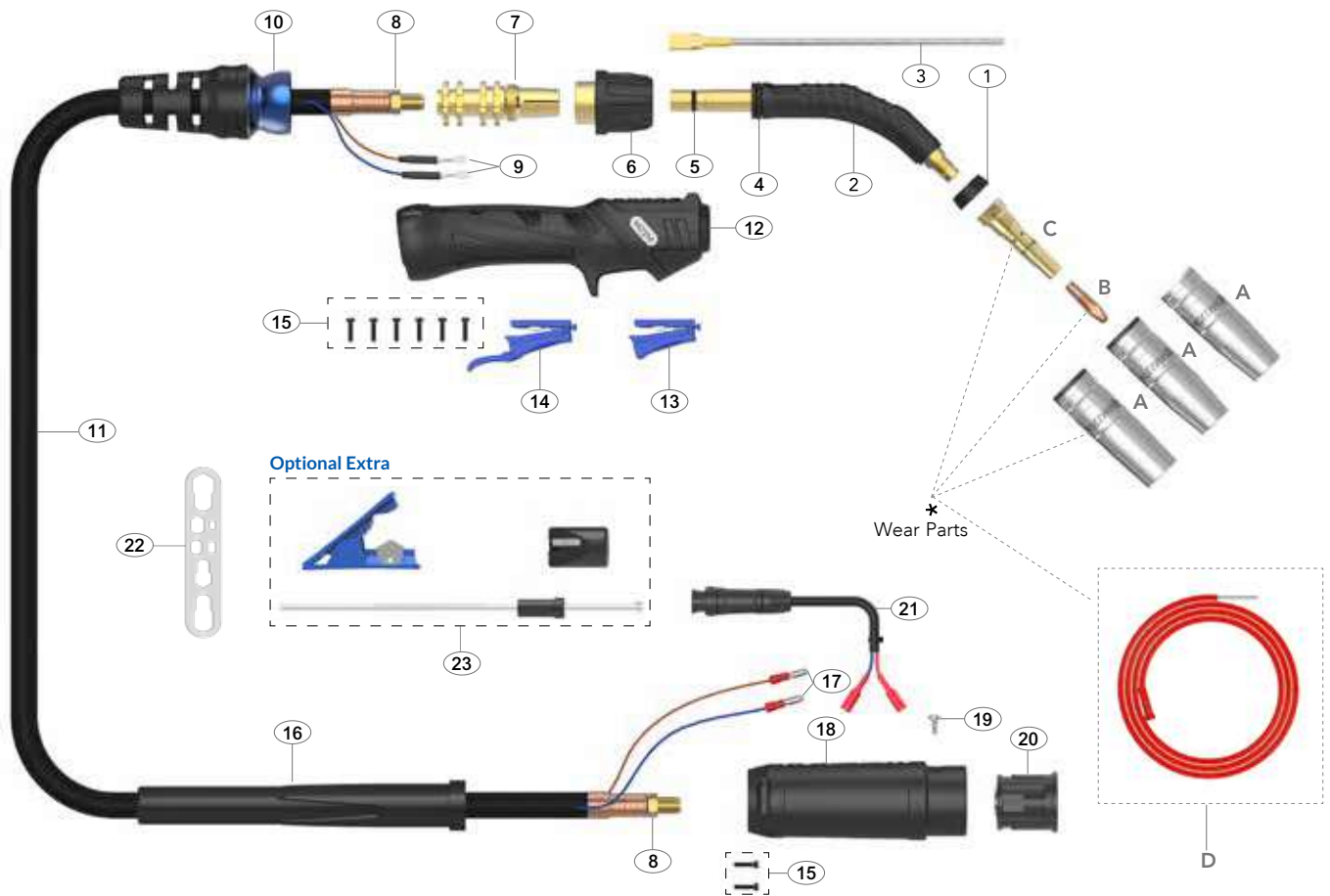

## Spare Parts

Part Number	Description
1 AM2AP	Neck Insulator
2 AM22001M	Swan Neck Assembly - Multijust
3 AM22MJL	Neck Jump Liner 0.8-1.2mm - Hard Wire
4 AM-MJ1509	Neck 'O' Ring(Ø14xØ2.5)
5 AM-MJ1508	Neck 'O' Ring(Ø8.5xØ1.5)
6 AM1516M	Neck Nut - Multijust
7 AM1515M	Socket Connection
8 AM1505	Lock Nut
9 AM1521	Cable Terminal
10 AM1514	Handle Cable Support c/w Ball Joint
11 AM2603-30	Ultraflex Cable Assembly x 3mt
AM2603-40	Ultraflex Cable Assembly x 4mt
AM2603-50	Ultraflex Cable Assembly x 5mt
12 AM2514	Handle Kit
13 AM2516	Microswitch Standard Trigger
14 AM2516L	Microswitch Extended Trigger
15 AMSP1-1	Screw Pack
16 AMPA3541	Cable Support
17 AM1522	Cable Terminal Male
18 AM2578H/L	Gun Plug Housing
19 AML1541	Gun Plug Screw
20 AM-ECCEM1528-2	Hybrid Plug body
21 AMQF-SW	Male Switch Wire Plug

Part Number	Description
22 AMWS	Wear Parts Spanner
<b>Optional Extra</b>	
23 AMCLST-KITS	Combi-Liner Set-up kit-Optional

### Welding with Soft Wires

For welding with Aluminum wires use a Combi-liner (page 31). Optimum installation is achieved when using the Combi-liner set-up kit.

# M3 <sup>New</sup> Air-Cooled Mig Welding Torch

Ratings:	300A CO <sub>2</sub> , 270A mixed gas M21, EN60974-7 @ 60% duty cycle. 0.9mm-1.2mm wires
----------	---

The Arc M3 is a true 300 Amp Torch which outperforms all Binzel® MB36 derivatives and is ideal for 1.2mm production work.



## ARC M HIGH PERFORMANCE MIG TORCH PACKAGES

M3 Torches are supplied with a Euro termination as standard and are supplied 'ready to weld' with all wear parts fitted.



<b>3mt</b> <b>M3-3M-AD</b>	<b>4mt</b> <b>M3-4M-AD</b>	<b>5mt</b> <b>M3-5M-AD</b>
-------------------------------	-------------------------------	-------------------------------



### Wear Parts

#### Nozzles - 2 Piece

	Part Number	Description	Bore	Wall	Material
A	AM3HDTN	Tapered Nozzle (Part 2)	12mm	3mm	Copper
	•AM3HDCN	Conical Nozzle (Part 2)	14mm	3mm	Copper
	AM3HDCYN	Cylindrical Nozzle (Part 2)	19mm	3mm	Copper
A1	•AM3HDNI	Nozzle Insulator(Part 1)			Copper

#### Nozzles - Single Piece

A2	AM3TN	Tapered Nozzle / Insulator Assy	12mm	2.25mm	Copper
	AM3CN	Conical Nozzle / Insulator Assy	14mm	2.25mm	Copper
	AM3CYN	Cylindrical Nozzle / Insulator Assy	19mm	2.25mm	Copper

#### B Contact Tips

	Part Number	Description	Size (mm)	Wire Size (mm-inch)	Material
<b>Standard Series</b>					
	AM5CT09	Contact Tip	M8*29.5	0.9-0.035	CuCrZr
	AM5CT10	Contact Tip	M8*29.5	1.0-0.040	CuCrZr
	•AM5CT12	Contact Tip	M8*29.5	1.2-0.045	CuCrZr
<b>A Series</b>					
	AM5CT10A	Contact Tip	M8*29.5	1.0-0.040	CuCrZr
	AM5CT12A	Contact Tip	M8*29.5	1.2-0.045	CuCrZr
	AM2CT10A	Contact Tip	M8*29.5	1.0-0.040	Copper
	AM2CT12A	Contact Tip	M8*29.5	1.2-0.045	Copper

#### C Tip Adaptors

Part Number	Description	Material
•AM3TAB	Tip Adaptor	Brass
AM3TAC	Tip Adaptor High Performance	CuCrZr

#### D Liners

Part Number	Description	Wire Size
•AM2524-30	Steel Liner x 3mt	1.0-1.2mm
•AM2524-40	Steel Liner x 4mt	1.0-1.2mm
•AM2524-50	Steel Liner x 5mt	1.0-1.2mm
AM1535-30	Steel Liner x 3mt	0.6-0.9mm
AM1535-40	Steel Liner x 4mt	0.6-0.9mm
AM1535-50	Steel Liner x 5mt	0.6-0.9mm

•Denotes torch package standard wear part set-up

**SuperSoft -20** Premium Power Cables  
Perfect for extreme subzero working conditions

® All Trademarks are the property of their respective owners and usage is for cross reference only

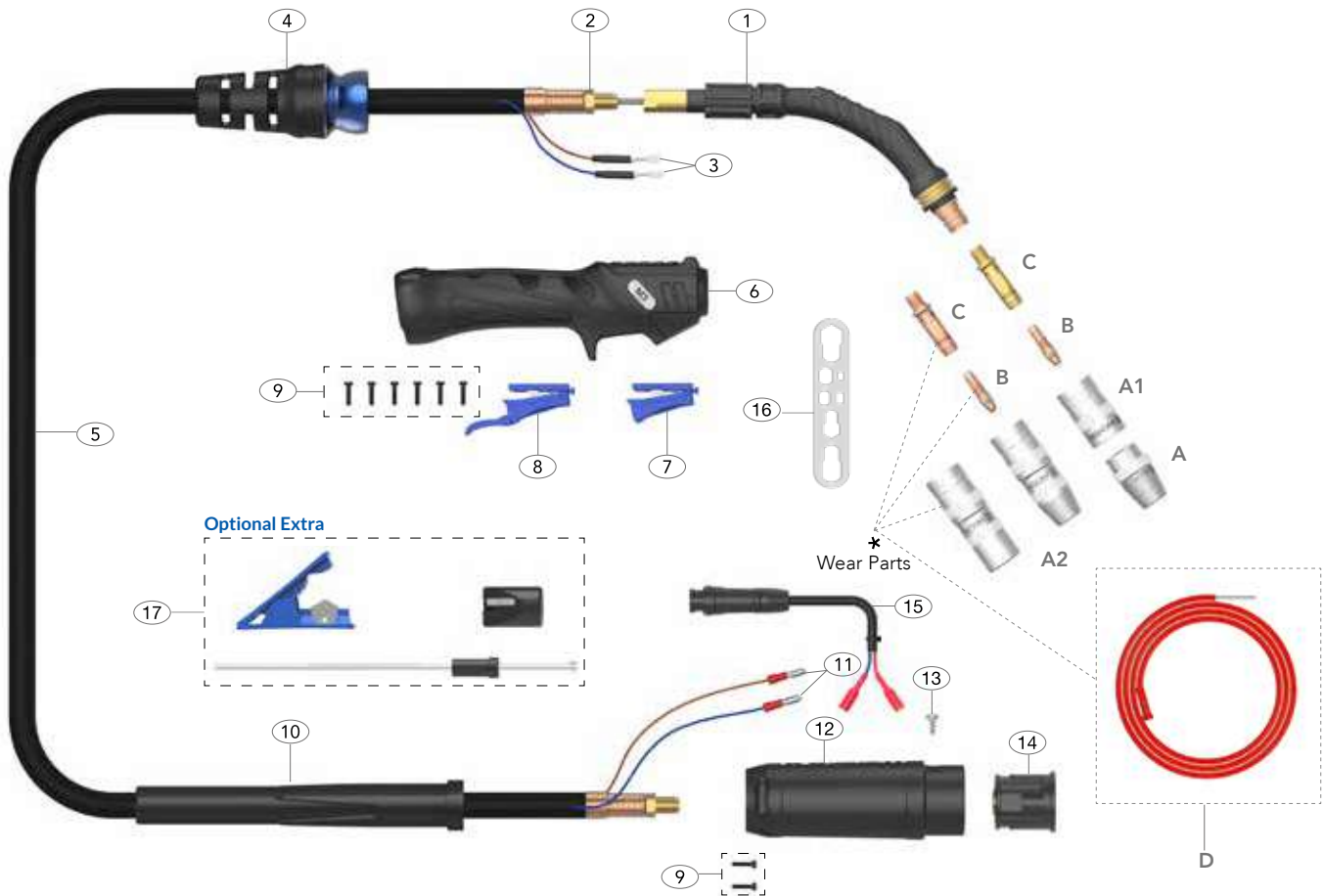

## Spare Parts

Part Number	Description
1 AM3001	Swan Neck Assembly
2 AM1505	Lock Nut
3 AM1521	Cable Terminal
4 AM1514	Handle Cable Support c/w Ball Joint
5 AM3003CW-30	Power Cable Assembly x 3mt
AM3003CW-40	Power Cable Assembly x 4mt
AM3003CW-50	Power Cable Assembly x 5mt
6 AM2514	Handle Kit
7 AM2516	Microswitch Standard Trigger
8 AM2516L	Microswitch Extended Trigger
9 AMSP1-1	Screw Pack
10 AMPA3541	Cable Support
11 AM1522	Cable Terminal Male
12 AM2578H/L	Gun Plug Housing
13 AML1541	Gun Plug Screw
14 AM-ECEM1528-2	Hybrid Plug body
15 AMQF-SW	Male Switch Wire Plug

Part Number	Description
16 AMWS	Wear Parts Spanner
<b>Optional Extra</b>	
17 AMCLST-KITS	Combi-Liner Set-up kit

### Welding with Soft Wires

For welding with Aluminum wires use a Combi-liner (page 38-39). Optimum installation is achieved when using the Combi-liner set-up kit.

# M4 <sup>New</sup> Air-Cooled Mig Welding Torch



Ratings:	350A CO <sub>2</sub> , 320A mixed gas M21, EN60974-7 @ 60% duty cycle. 0.9mm-1.2mm wires
----------	---

The Arc M4 performance is superior to the Binzel® MB36 and delivers more power than an MB38.

An all-day production torch in solid wire and pulse Mig applications over 300 Amps.

## ARC M HIGH PERFORMANCE MIG TORCH PACKAGES

M4 Torches are supplied with a Euro termination as standard and are supplied 'ready to weld' with all wear parts fitted.



### Wear Parts

#### Nozzles - 2 Piece

	Part Number	Description	Bore	Wall	Material
A	AM4HDTN	Tapered Nozzle (Part 2)	13mm	3mm	Copper
	•AM4HDCN	Conical Nozzle (Part 2)	15mm	3mm	Copper
	AM4HDCYN	Cylindrical Nozzle (Part 2)	21mm	3mm	Copper
A1	•AM4HDNI	Nozzle Insulator(Part 1)			Copper

#### Nozzles - Single Piece

	Part Number	Description	Bore	Wall	Material
A2	AM4TN	Tapered Nozzle / Insulator Assy	13mm	2.25mm	Copper
	AM4CN	Conical Nozzle / Insulator Assy	15mm	2.25mm	Copper
	AM4CYN	Cylindrical Nozzle / Insulator Assy	21mm	2.25mm	Copper

#### B Contact Tips

	Part Number	Description	Size (mm)	Wire Size (mm-inch)	Material
<b>Standard Series</b>					
	AM6WCT09	Contact Tip	M10*35.5	0.9 - 0.035	CuCrZr
	AM6WCT10	Contact Tip	M10*35.5	1.0 - 0.040	CuCrZr
	•AM6WCT12	Contact Tip	M10*35.5	1.2 - 0.045	CuCrZr
<b>A Series</b>					
	AM6WCT10A	Contact Tip	M10*35.5	1.0 - 0.040	CuCrZr
	AM6WCT12A	Contact Tip	M10*35.5	1.2 - 0.045	CuCrZr
	AMC6WCT10A	Contact Tip	M10*35.5	1.0 - 0.040	Copper
	AMC6WCT12A	Contact Tip	M10*35.5	1.2 - 0.045	Copper

#### C Tip Adaptors

Part Number	Description	Material
•AM4TAB	Tip Adaptor	Brass
AM4TAC	Tip Adaptor High Performance	CuCrZr

#### D Liners

Part Number	Description	Wire Size
•AM2524-30	Steel Liner x 3mt	1.0-1.2mm
•AM2524-40	Steel Liner x 4mt	1.0-1.2mm
•AM2524-50	Steel Liner x 5mt	1.0-1.2mm
AM1535-30	Steel Liner x 3mt	0.6-0.9mm
AM1535-40	Steel Liner x 4mt	0.6-0.9mm
AM1535-50	Steel Liner x 5mt	0.6-0.9mm

•Denotes torch package standard wear part set-up

**SuperSoft -20 Premium Power Cables**  
Perfect for extreme subzero working conditions

® All Trademarks are the property of their respective owners and usage is for cross reference only

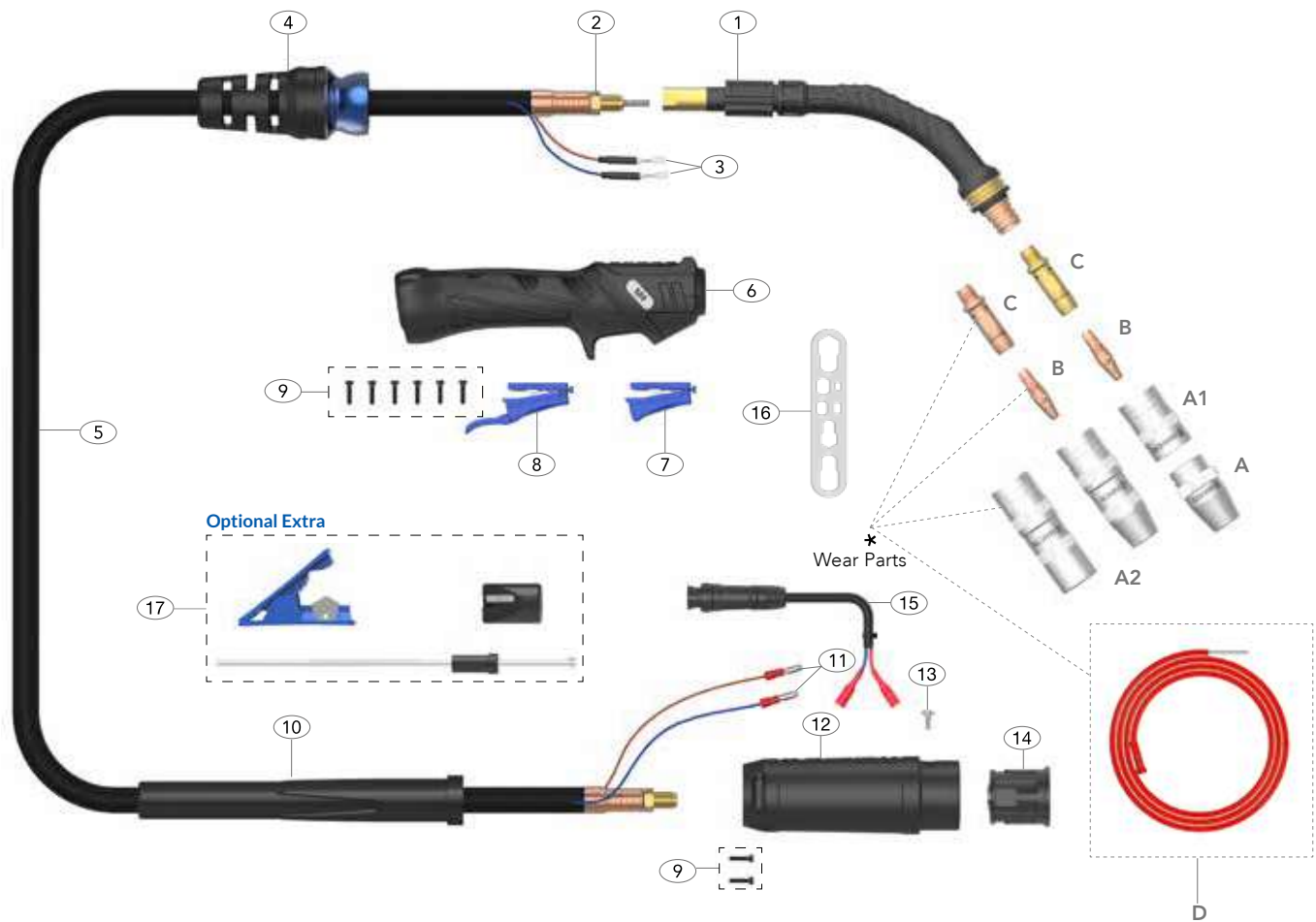

## Spare Parts

Part Number	Description
1 AM4001	Swan Neck Assembly
2 AM1505	Lock Nut
3 AM1521	Cable Terminal
4 AM1514	Handle Cable Support c/w Ball Joint
5 AM4003CW-30	Power Cable Assembly x 3mt
AM4003CW-40	Power Cable Assembly x 4mt
AM4003CW-50	Power Cable Assembly x 5mt
6 AM2514	Handle Kit
7 AM2516	Microswitch Standard Trigger
8 AM2516L	Microswitch Extended Trigger
9 AMSP1-1	Screw Pack
10 AMPA3541	Cable Support
11 AM1522	Cable Terminal Male
12 AM2578H/L	Gun Plug Housing
13 AML1541	Gun Plug Screw
14 AM-ECEM1528-2	Hybrid Plug body
15 AMQF-SW	Male Switch Wire Plug

Part Number	Description
16 AMWS	Wear Parts Spanner
<b>Optional Extra</b>	
17 AMCLST-KITS	Combi-Liner Set-up kit

### Welding with Soft Wires

For welding with Aluminum wires use a Combi-liner (page 38-39). Optimum installation is achieved when using the Combi-liner set-up kit.

# M5 Air-Cooled Mig Welding Torch

Ratings:	390A CO <sub>2</sub> , 360A mixed gas M21, EN60974-7 @ 60% duty cycle. 0.9mm-1.6mm wires
----------	---

Constructed for power, performance, and longevity the M5 is ideal for heavy duty 1.2mm and 1.6mm high deposition and pulse applications.

A retrofit heat shield is available for high reflected heat applications.



M5 Video

## ARC M HIGH PERFORMANCE MIG TORCH PACKAGES

M5 Torches are supplied with a Euro termination as standard and are supplied 'ready to weld' with all wear parts fitted.



### Wear Parts

#### Nozzle - 2 Piece

Part Number	Description	Bore	Wall	Material
A AM5HDTN	Tapered Nozzle - (Part 2)	13mm	3.5mm	Copper
•AM5HDCN	Conical Nozzle - (Part 2)	15mm	3.5mm	Copper
AM5HDCYN	Cylindrical Nozzle - (Part 2)	21mm	3.5mm	Copper
A1•AM5HDNI	Nozzle Insulator - (Part 1)			Copper

#### Nozzle - Single Piece

A2 AM5TN	Tapered Nozzle / Insulator Assy	13mm	2.5mm	Copper
AM5CN	Conical Nozzle / Insulator Assy	15mm	2.5mm	Copper
AM5CYN	Cylindrical Nozzle / Insulator Assy	21mm	2.5mm	Copper

#### B Contact Tips

Part Number	Description	Size (mm)	Wire Size (mm-inch)	Material
<b>Standard Series</b>				
AM6WCT09	Contact Tip	M10*35.5	0.9 - 0.035	CuCrZr
AM6WCT10	Contact Tip	M10*35.5	1.0 - 0.040	CuCrZr
•AM6WCT12	Contact Tip	M10*35.5	1.2 - 0.045	CuCrZr
AM6WCT14	Contact Tip	M10*35.5	1.4 - 0.055	CuCrZr
AM6WCT16	Contact Tip	M10*35.5	1.6 - 0.063	CuCrZr
AM6WCT20	Contact Tip	M10*35.5	2.0 - 0.080	CuCrZr
<b>A Series</b>				
AM6WCT10A	Contact Tip	M10*35.5	1.0 - 0.040	CuCrZr
AM6WCT12A	Contact Tip	M10*35.5	1.2 - 0.045	CuCrZr
AM6WCT16A	Contact Tip	M10*35.5	1.6 - 0.063	CuCrZr
AMC6WCT10A	Contact Tip	M10*35.5	1.0 - 0.040	Copper
AMC6WCT12A	Contact Tip	M10*35.5	1.2 - 0.045	Copper

#### Tip Adaptors

Part Number	Description	Material
AM5TAC	Tip Adaptor High Performance	CuCrZr
•AM5TAB	Tip Adaptor	Brass

#### D Liners

Part Number	Description	Wire Size
•AM6SL-1012-30	Steel Liner x 3mt	1.0-1.2mm
•AM6SL-1012-40	Steel Liner x 4mt	1.0-1.2mm
•AM6SL-1012-50	Steel Liner x 5mt	1.0-1.2mm
AM6SL-16-30	Steel Liner x 3mt	1.6mm
AM6SL-16-40	Steel Liner x 4mt	1.6mm
AM6SL-16-50	Steel Liner x 5mt	1.6mm

• Denotes torch package standard wear part set-up

**SuperSoft -20 Premium Power Cables**  
Perfect for extreme subzero working conditions



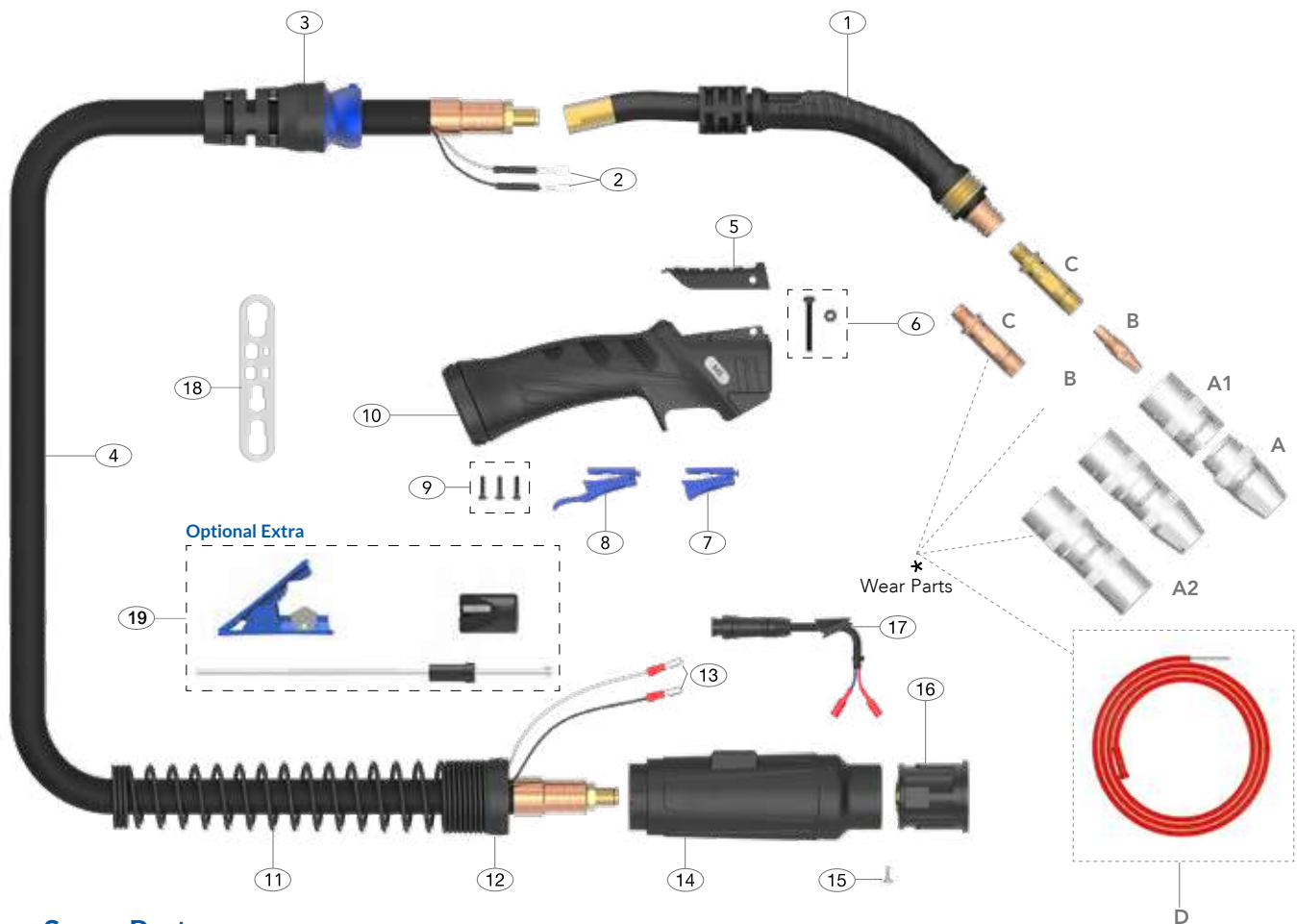

## Spare Parts

Part Number	Description
1 AM5001	Swan Neck Assembly
2 AM1521	Cable Terminal
3 AMS8017	Handle Cable Support c/w Ball Jiont
4 AM5003CW-30	Power Cable Assembly x 3mt
AM5003CW-40	Power Cable Assembly x 4mt
AM5003CW-50	Power Cable Assembly x 5mt
5 AM2515-C	Handle Control Cover
6 AMDMNS	Screw and Nut
7 AM2516	Microswitch Standard Trigger
8 AM2516L	Microswitch Extended Trigger
9 AMSP1-1	Screw Pack
10 AM2515	Handle and Lock Nut Assembly
11 AM8026	Housing Spring
12 AM8028	Housing Lock Nut
13 AM1522	Cable Terminal Male

Part Number	Description
14 AMT5022	Gun Plug Housing
15 AML1541	Gun Plug Screw
16 AM-ECCEM1575-2	Hybrid Plug Body
17 AMQF-SW-C	Male Switch Wire Plug With Cover
18 AMWS	Wear Parts Spanner
<b>Optional Extra</b>	
19 AMCLST-KITS	Combi-Liner Set-up kit-Optional

### Welding with Soft Wires

For welding with Aluminum wires use a Combi-liner (page 38-39). Optimum installation is achieved when using the Combi-liner set-up kit.

# M6 Air-Cooled Mig Welding Torch

Ratings:	430A CO <sub>2</sub> , 400A mixed gas M21, EN60974-7 @ 60% duty cycle. 0.9mm-2.0mm wires
----------	---

**An Indestructible 400 Amp Air-Cooled Production Torch.**  
**Perfect for high amps, high deposition, pulse, and high duty applications with 1.2mm and 1.6mm wires.**  
**A retrofit heat shield is available for high reflected heat applications.**

## ARC M HIGH PERFORMANCE MIG TORCH PACKAGES

M6 Torches are supplied with a Euro termination as standard and are supplied 'ready to weld' with all wear parts fitted.

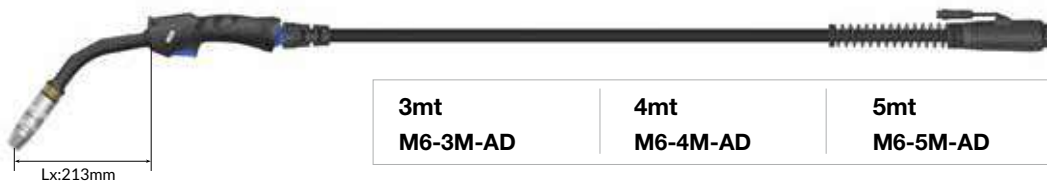

### Wear Parts

#### Nozzle - 2 Piece

Part Number	Description	Bore	Wall	Material
A AM6HDTN	Tapered Nozzle (Part 2)	13mm	3.5mm	Copper
•AM6HDCN	Conica Nozzle (Part 2)	15mm	3.5mm	Copper
AM6HDCYN	Cylindrical Nozzle (Part 2)	23mm	3.5mm	Copper
A1•AM6HDNI	Nozzle Insulator(Part 1)			Copper

#### Nozzle - Single Piece

A2 AM6TN	Tapered Nozzle / Insulator Assy	13mm	2.5mm	Copper
AM6CN	Conical Nozzle / Insulator Assy	15mm	2.5mm	Copper
AM6CYN	Cylindrical Nozzle / Insulator Assy	23mm	2.5mm	Copper

#### B Contact Tips

Part Number	Description	Size (mm)	Wire Size (mm-inch)	Material
<b>Standard Series</b>				
AM6CT09	Contact Tip	M12*40.5	0.9 - 0.035	CuCrZr
AM6CT10	Contact Tip	M12*40.5	1.0 - 0.040	CuCrZr
•AM6CT12	Contact Tip	M12*40.5	1.2 - 0.045	CuCrZr
AM6CT14	Contact Tip	M12*40.5	1.4 - 0.055	CuCrZr
AM6CT16	Contact Tip	M12*40.5	1.6 - 0.063	CuCrZr
AM6CT20	Contact Tip	M12*40.5	2.0 - 0.080	CuCrZr
<b>A Series</b>				
AM6CT10A	Contact Tip	M12*40.5	1.0 - 0.040	CuCrZr
AM6CT12A	Contact Tip	M12*40.5	1.2 - 0.045	CuCrZr
AM6CT16A	Contact Tip	M12*40.5	1.6 - 0.063	CuCrZr
AM6CT20A	Contact Tip	M12*40.5	2.0 - 0.080	CuCrZr
AMC6CT10A	Contact Tip	M12*40.5	1.0 - 0.040	Copper
AMC6CT12A	Contact Tip	M12*40.5	1.2 - 0.045	Copper

#### C Tip Adaptors

Part Number	Description	Material
•AM6TAC	Tip Adaptor High Performance	CuCrZr
AM6TAB	Tip Adaptor	Brass

#### D Liners

Part Number	Description	Wire Size
•AM6SL-1012-30	Steel Liner x 3mt	1.0-1.2mm
•AM6SL-1012-40	Steel Liner x 4mt	1.0-1.2mm
•AM6SL-1012-50	Steel Liner x 5mt	1.0-1.2mm
AM6SL-16-30	Steel Liner x 3mt	1.6mm
AM6SL-16-40	Steel Liner x 4mt	1.6mm
AM6SL-16-50	Steel Liner x 5mt	1.6mm

• Denotes torch package standard wear part set-up

**SuperSoft -20 Premium Power Cables**  
 Perfect for extreme subzero working conditions

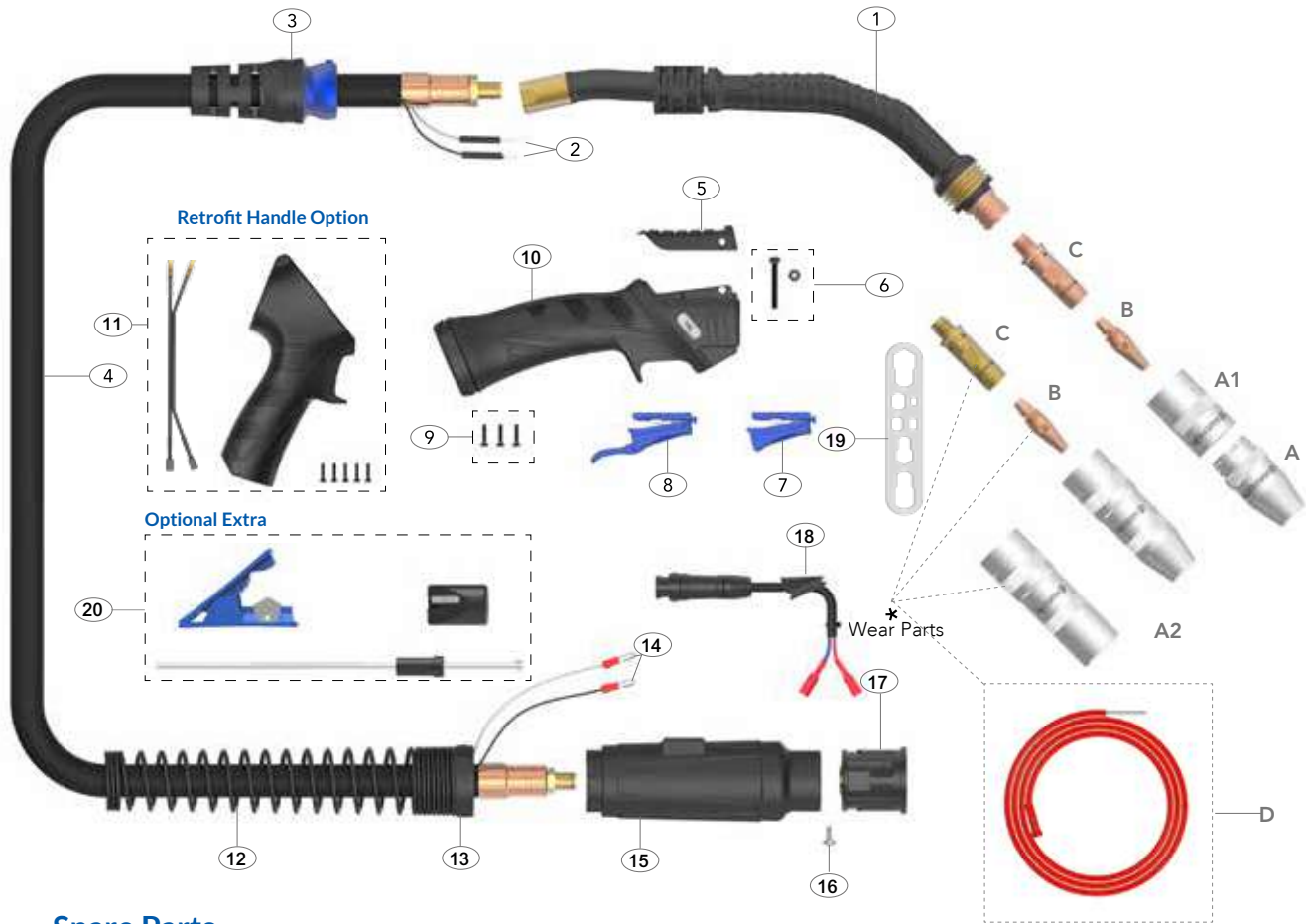

## Spare Parts

Part Number	Description
1 AM6001	Swan Neck Assembly
2 AM1521	Cable Terminal
3 AMS8017	Handle Cable Support c/w Ball Joint
4 AM6003CW-30	Power Cable Assembly x 3mt
AM6003CW-40	Power Cable Assembly x 4mt
AM6003CW-50	Power Cable Assembly x 5mt
5 AM2515-C	Handle Control Cover
6 AMDMNS	Screw and Nut
7 AM2516	Microswitch Standard Trigger
8 AM2516L	Microswitch Extended Trigger
9 AMSP1-1	Screw Pack
10 AM2515	Handle and Lock Nut Assembly
12 AM8026	Housing Spring
13 AM8028	Housing Lock Nut
14 AM1522	Cable Terminal Male
15 AMT5022	Gun Plug Housing
16 AML1541	Gun Plug Screw
17 AM-ECEM1575-2	Hybrid Plug Body

Part Number	Description
18 AMQF-SW-C	Male Switch Wire Plug With Cover
19 AMWS	Wear Parts Spanner
<b>Optional Extra</b>	
20 AMCLST-KITS	Combi-Liner Set-up kit-Optional

## Retrofit Handle Option

Part Number	Description
11 AMMP2515	Pistol Handle Assembly

## Welding with Soft Wires

For welding with Aluminum wires use a Combi-liner (page 38-39). Optimum installation is achieved when using the Combi-liner set-up kit.

# Universal Kits

## Connector Kits



**MAKE WORK**  
LIFE EASIER

### Tweco® Universal Kits

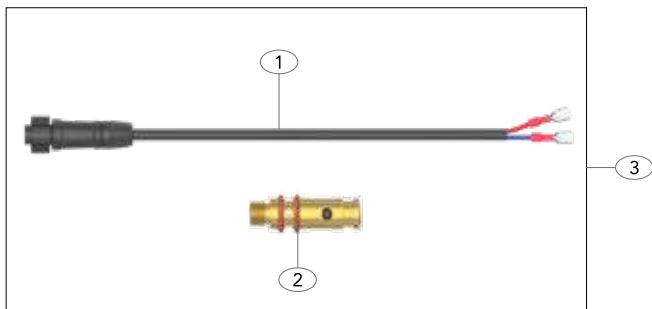

Direct Plug Connector	
Part Number	Description
1 AM-ECEL1575-SW-Q	Quick Fit Switch Wire Assembly
2 AM-ECEAT1528-1	Tweco® 1-4 Power Pin
3 AM-ECEAT1528K-Q	Quick Fit Connector Kit Complete

### Miller® Universal Kits

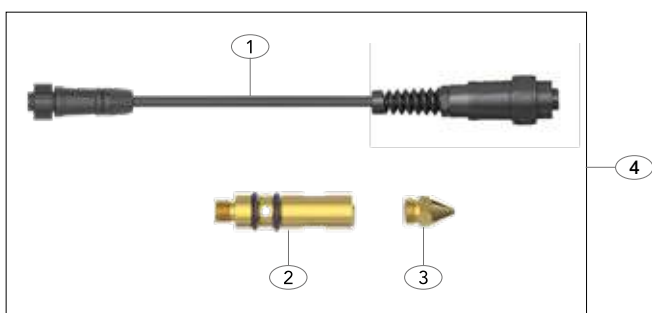

Direct Plug Connector	
Part Number	Description
1 AM-ECEM1575-SW-Q	Quick Fit Miller® Plug Assembly
2 AM-ECEAM1528-1	Miller® Power Pin
3 AM-ML1570	Wire Guide 0.35"×1/16"
AM-ML1571	Wire Guide 5/16-3/32"(Option)
4 AM-ECEAM1528K-Q	Quick Fit Connector Kit Complete

### Lincoln® Universal Kits

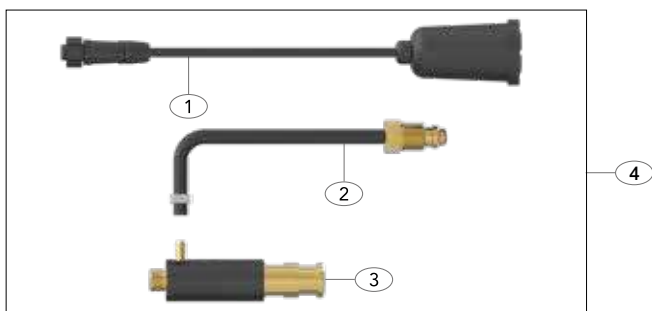

Direct Plug Connector	
Part Number	Description
1 AM-M16725-Q	Quick Fit Lincoln® Plug Assembly
2 AM-ECEL1575N-G	Lincoln® Gas Tube Assembly
3 AM-ECEAL1528	Lincoln® Power Pin Assembly
4 AM-ECEAL1528K-Q	Quick Fit Connector Kit Complete

### Panasonic® Universal Kits

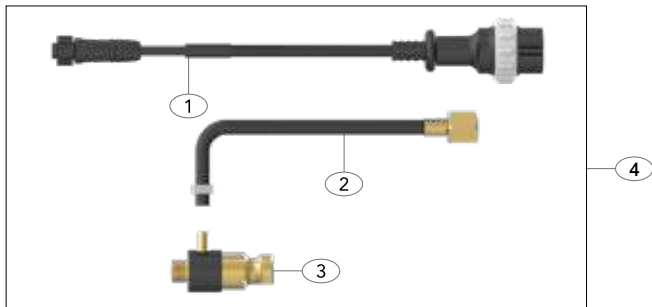

Direct Plug Connector	
Part Number	Description
1 AM-PA1812-Q	Quick Fit Panasonic® Plug Assembly
2 AM-PN1811N-G	Panasonic® Gas Tube Assembly
3 AM-ECEAP1528	Panasonic® Power Pin Assembly
4 AM-ECEAP1528-Q	Quick Fit Connector Kit Complete



Universal Set-up Guide  
A simple step by step guide

# Universal Kits

## Connector Kits



**MAKE WORK**  
LIFE EASIER

### LPW Universal Kits

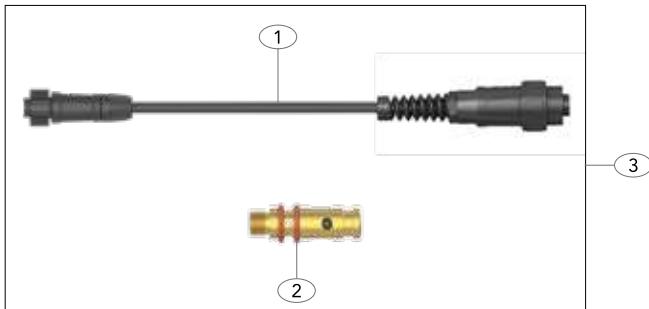

Direct Plug Connector	
Part Number	Description
1 AM-ECM1575-SW-Q	Quick Fit Miller® Plug Assembly
2 AM-ECEAT1528-1	Tweco® 1-4 Power Pin
3 AM-ECEAW1528K-Q	Quick Fit Connector Kit Complete

### LPB Universal Kits

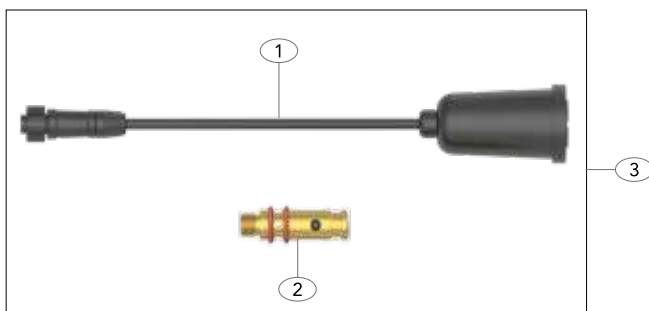

Direct Plug Connector	
Part Number	Description
1 AM-M16725-Q	Quick Fit Lincoln® Plug Assembly
2 AM-ECEAT1528-1	Tweco® 1-4 Power Pin
3 AM-ECEAB1528K-Q	Quick Fit Connector Kit Complete

### Euro Universal Kits M1/M18/M2/M22/M2M/M22M

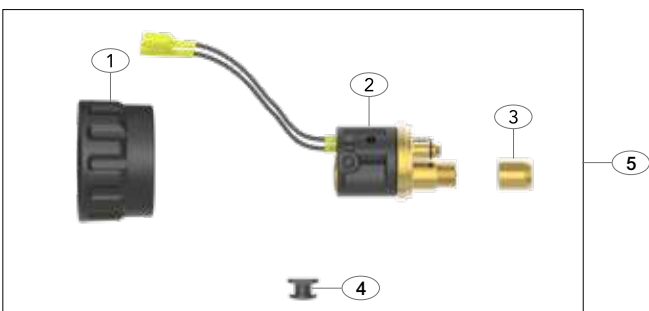

Direct Plug Connector	
Part Number	Description
1 AMC1519/S	Gun Plug Nut
2 AM1528	Hybrid Gun Plug Body c/w Spring Pins
3 AM1826	Liner Retaining Nut
4 AM2578-SP2	Housing Stopper
5 AM1528K-Q	Quick Fit Connector Kit Complete

### Euro Universal Kits M3

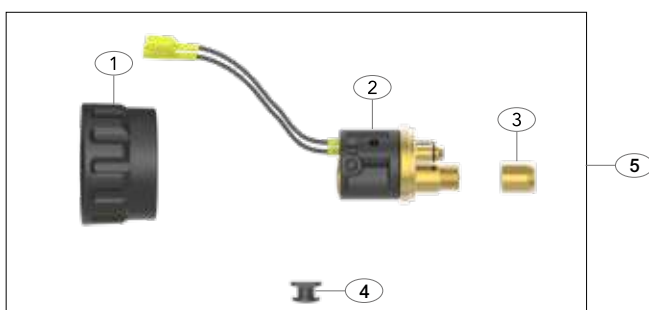

Direct Plug Connector	
Part Number	Description
1 AMC1519	Gun Plug Nut
2 AM1528	Hybrid Gun Plug Body c/w Spring Pins
3 AM1826	Liner Retaining Nut
4 AM2578-SP2	Housing Stopper
5 AM1528SK-Q	Quick Fit Connector Kit Complete



**Universal Set-up Guide**  
A simple step by step guide

The design, manufacturing and quality systems of Arc Torchology are certified by **BVQI** in accordance with EN/ISO 9001:2015

# Universal Kits

## Connector Kits

### Euro Universal Kits M4

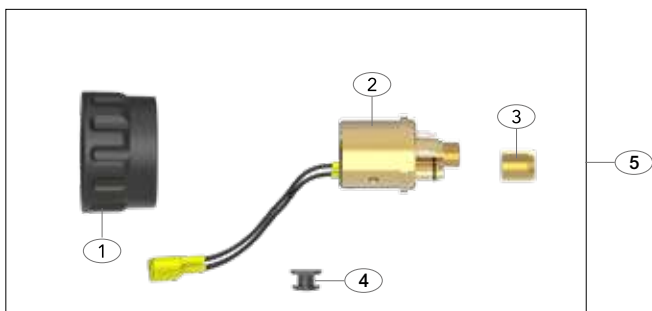

Direct Plug Connector	
Part Number	Description
1 AMC1519	Gun Plug Nut
2 AMB1528S	Gun Plug Body
3 AM1826	Liner Retaining Nut
4 AM2578-SP2	Housing Stopper
5 AMB1528SK-Q	Quick Fit Connector Kit Complete

### Euro Connector Kits M5/M6

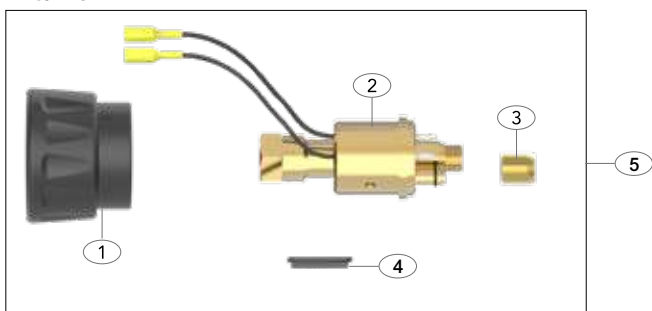

Direct Plug Connector	
Part Number	Description
1 AM1519	Gun Plug Nut
2 AMB1528	Gun Plug Body
3 AM1826	Liner Retaining Nut
4 AMF8017	Large Housing Flat Cover Block
5 AMB1528K-Q	Quick Fit Connector Kit Complete



Universal Set-up Guide  
A simple step by step guide

### Nozzles

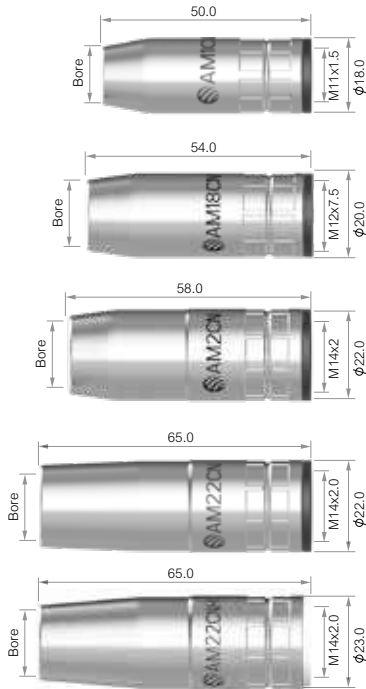

Part No.	Description	Bore	Wall	Material	M1	M18	M2	M22	M2M	M22M
AM1CN	Conical Nozzle Assembly	12mm	1.0mm	Copper	●	●	●	●	●	●
AM1TN	Tapered Nozzle Assembly	10.6mm	1.0mm	Copper	●	●	●	●	●	●
AM18CN	Conical Nozzle Assembly	14mm	1.5mm	Copper	●	●	●	●	●	●
AM18TN	Tapered Nozzle Assembly	12mm	1.5mm	Copper	●	●	●	●	●	●
AM2CN	Conical Nozzle Assembly	15mm	1.9mm	Copper	●	●	●	●	●	●
AM2TN	Tapered Nozzle Assembly	12mm	1.9mm	Copper	●	●	●	●	●	●
AM22CN	Conical Nozzle Assembly	16mm	1.75mm	Copper	●	●	●	●	●	●
AM22TN	Tapered Nozzle Assembly	14mm	1.75mm	Copper	●	●	●	●	●	●
Recommended for High Amperage and Pulse Welding										
AM22CNHD	Conical Nozzle HD Assembly	16mm	2.00mm	Copper	●	●	●	●	●	●

### Contact Tips

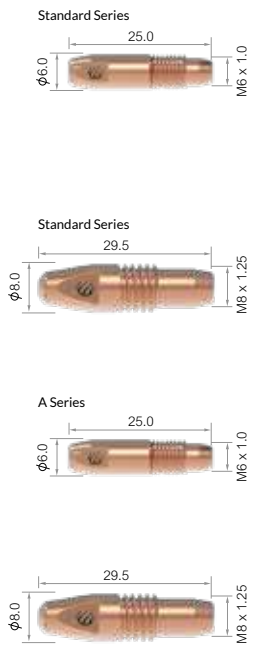

Part No.	Description	Size mm	Wire Size mm-Inch	Material	M1	M18	M2	M22	M2M	M22M
<b>Standard Series</b> - Recommended for Fe, Fe-MC/FC Set-up										
AM1CT06	Contact Tip	M6*25.0	0.6-0.023	Copper	●	●	●	●	●	●
AM1CT08	Contact Tip	M6*25.0	0.8-0.030	Copper	●	●	●	●	●	●
AM1CT09	Contact Tip	M6*25.0	0.9-0.035	Copper	●	●	●	●	●	●
AM1CT10	Contact Tip	M6*25.0	1.0-0.040	Copper	●	●	●	●	●	●
AM1CT12	Contact Tip	M6*25.0	1.2-0.045	Copper	●	●	●	●	●	●
<b>Standard Series</b> - Recommended for Fe, Fe-MC/FC Set-up										
AM2CT08	Contact Tip	M8*29.5	0.8-0.030	Copper	●	●	●	●	●	●
AM2CT09	Contact Tip	M8*29.5	0.9-0.035	Copper	●	●	●	●	●	●
AM2CT10	Contact Tip	M8*29.5	1.0-0.040	Copper	●	●	●	●	●	●
AM2CT12	Contact Tip	M8*29.5	1.2-0.045	Copper	●	●	●	●	●	●
<b>A Series</b> - Recommended for Aluminium and SS Set-up										
AM1CT08A	Contact Tip	M6*25.0	0.8-0.030	Copper	●	●	●	●	●	●
AM1CT10A	Contact Tip	M6*25.0	1.0-0.040	Copper	●	●	●	●	●	●
AM1CT12A	Contact Tip	M6*25.0	1.2-0.045	Copper	●	●	●	●	●	●
<b>A Series</b> - Recommended for Aluminium and SS Set-up										
AM2CT08A	Contact Tip	M8*29.5	0.8-0.030	Copper	●	●	●	●	●	●
AM2CT10A	Contact Tip	M8*29.5	1.0-0.040	Copper	●	●	●	●	●	●
AM2CT12A	Contact Tip	M8*29.5	1.2-0.045	Copper	●	●	●	●	●	●

● Standard wear part range ● Torch package standard wear part set-up

### Tip Adaptors

Part No.	Description	Material	M1	M18	M2	M22	M2M	M22M
AM1TA	Tip Adaptor	Brass	●	●	●	●	●	●
AM18TA	Tip Adaptor	Brass	●	●	●	●	●	●
AM2TA	Tip Adaptor	Brass	●	●	●	●	●	●
AM22TA	Tip Adaptor	Brass	●	●	●	●	●	●





## Liners

### Filler Metal

**Steel Liner** Recommended for: Fe, Fe-MC/FC. Light and medium duty applications

Part No.	Description	Nipple	Wire Size mm	M1	M18	M2	M22	M2M	M22M
AM1535-30	Steel Liner x 3mt	Moulded Nipple	0.6-0.9	●	●	●	●	●	●
AM1535-40	Steel Liner x 4mt	Moulded Nipple	0.6-0.9	●	●	●	●	●	●
AM1535-50	Steel Liner x 5mt	Moulded Nipple	0.6-0.9	●	●	●	●	●	●



AM2524-30	Steel Liner x 3mt	Moulded Nipple	1.0-1.2	●	●	●	●	●	●
AM2524-40	Steel Liner x 4mt	Moulded Nipple	1.0-1.2	●	●	●	●	●	●
AM2524-50	Steel Liner x 5mt	Moulded Nipple	1.0-1.2	●	●	●	●	●	●



AM2MJL	Neck Jump Liner - Hard Wire(L:170mm)	Brass Nipple	0.8-1.2	●	●	●	●	●	●
AM22MJL	Neck Jump Liner - Hard Wire(L:186.5mm)	Brass Nipple	0.8-1.2	●	●	●	●	●	●



**Al - Combi Liner** Recommended for: Air-cooled torches with AlMg. Can be used for SS-MC/FC wires

AM1564-30	Combi-Liner x 3mt	Brass Nipple	0.8-1.2	●	●	●	●	●	●
AM1564-40	Combi-Liner x 4mt	Brass Nipple	0.8-1.2	●	●	●	●	●	●
AM1564-50	Combi-Liner x 5mt	Brass Nipple	0.8-1.2	●	●	●	●	●	●



**Al - Soft Wire Liner** Recommended for: Air-cooled torches with AlMg. Can be used for SS-MC/FC wires

AM1564A-30	Soft Wire Liner x 3mt	Brass Nipple	0.8-1.2	●	●	●	●	●	●
AM1564A-40	Soft Wire Liner x 4mt	Brass Nipple	0.8-1.2	●	●	●	●	●	●
AM1564A-50	Soft Wire Liner x 5mt	Brass Nipple	0.8-1.2	●	●	●	●	●	●



AM2MJL-B	Neck Jump Liner - Soft Wire(L:170mm)	Brass Nipple	0.8-1.2	●	●	●	●	●	●
AM22MJL-B	Neck Jump Liner - Soft Wire(L:186.5mm)	Brass Nipple	0.8-1.2	●	●	●	●	●	●





#### Welding with Soft Wires

For welding with Aluminum wires use a Combi-liner.  
Optimum installation is achieved when using the Combi-liner set-up kit.

● Standard wear part range ● Torch package standard wear part set-up

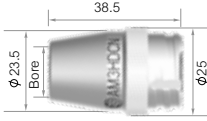
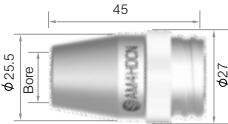
## Air-Cooled Nozzles - 2 Piece

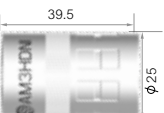
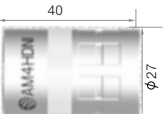
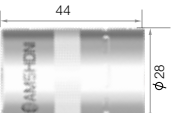
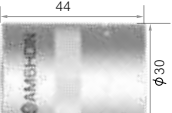
Part No.	Description	Bore	Wall		M3	M4	M5	M6	
	AM3HDTN AM3HDCN AM3HDCYN	Tapered Nozzle Conical Nozzle Cylindrical Nozzle	12mm 14mm 19mm	3mm 3mm 3mm	Copper Copper Copper	●	●	●	●
	AM4HDTN AM4HDCN AM4HDCYN	Tapered Nozzle Conical Nozzle Cylindrical Nozzle	13mm 15mm 21mm	3mm 3mm 3mm	Copper Copper Copper	●	●	●	●
	AM5HDTN AM5HDCN AM5HDCYN	Tapered Nozzle Conical Nozzle Cylindrical Nozzle	13mm 15mm 21mm	3.5mm 3.5mm 3.5mm	Copper Copper Copper	●	●	●	●
	AM6HDTN AM6HDCN AM6HDCYN	Tapered Nozzle Conical Nozzle Cylindrical Nozzle	13mm 15mm 23mm	3.5mm 3.5mm 3.5mm	Copper Copper Copper	●	●	●	●
	AM3HDNI	Nozzle Insulator				●	●	●	●
	AM4HDNI	Nozzle Insulator				●	●	●	●
	AM5HDNI	Nozzle Insulator				●	●	●	●
	AM6HDNI	Nozzle Insulator				●	●	●	●

● Standard wear part range ● Torch package standard wear part set-up

### Air-Cooled Nozzles - Single Piece

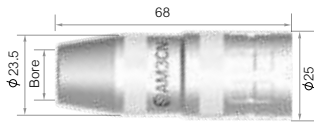

Part No.	Description	Bore	Wall	Material	M3	M4	M5	M6
AM3TN	Tapered Nozzle / Insulator Assy	12mm	2.25mm	Copper	●	●	●	●
AM3CN	Conical Nozzle / Insulator Assy	14mm	2.25mm	Copper	●	●	●	●
AM3CYN	Cylindrical Nozzle / Insulator Assy	19mm	2.25mm	Copper	●	●	●	●

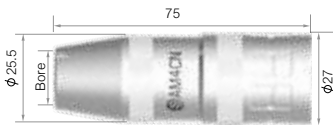

AM4TN	Tapered Nozzle / Insulator Assy	13mm	2.25mm	Copper	●	●	●	●
AM4CN	Conical Nozzle / Insulator Assy	15mm	2.25mm	Copper	●	●	●	●
AM4CYN	Cylindrical Nozzle / Insulator Assy	21mm	2.25mm	Copper	●	●	●	●

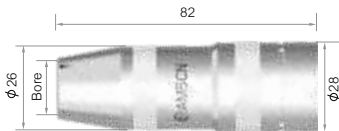

AM5TN	Tapered Nozzle / Insulator Assy	13mm	2.5mm	Copper	●	●	●	●
AM5CN	Conical Nozzle / Insulator Assy	15mm	2.5mm	Copper	●	●	●	●
AM5CYN	Cylindrical Nozzle / Insulator Assy	21mm	2.5mm	Copper	●	●	●	●

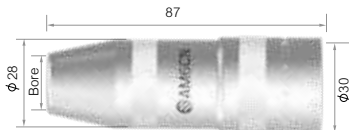

AM6TN	Tapered Nozzle / Insulator Assy	13mm	2.5mm	Copper	●	●	●	●
AM6CN	Conical Nozzle / Insulator Assy	15mm	2.5mm	Copper	●	●	●	●
AM6CYN	Cylindrical Nozzle / Insulator Assy	23mm	2.5mm	Copper	●	●	●	●

### Nozzle Performance Tests

How many nozzles do you use per day, per week, per year?

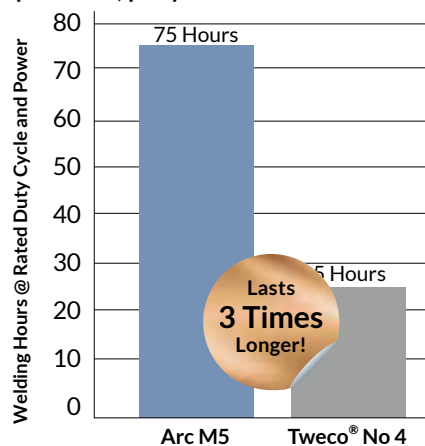

© All trademarks are the property of their respective owners and usage is for cross reference only

● Standard wear part range ● Torch package standard wear part set-up

## Contact Tips

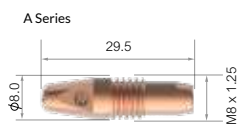
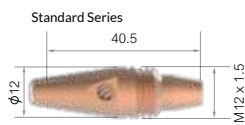
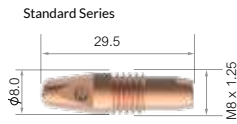

Part No.	Description	Size mm	Wire Size mm-inch	Material	Wire Type	M3 M4 M5 M6
<b>Standard Series</b> - Recommended for Fe, Fe-MC/FC Set-up						
AM5CT09	Contact Tip	M8*29.5	0.9-0.035	CuCrZr	Fe, Fe-FC/MC	● ● ● ●
AM5CT10	Contact Tip	M8*29.5	1.0-0.040	CuCrZr	SS,SS-FC/MC	● ● ● ●
AM5CT12	Contact Tip	M8*29.5	1.2-0.045	CuCrZr	upto 1.2mm	● ● ● ●

<b>Standard Series</b> - Recommended for Fe, Fe-MC/FC Set-up						
AM6CT09	Contact Tip	M12*40.5	0.9-0.035	CuCrZr		● ● ● ●
AM6CT10	Contact Tip	M12*40.5	1.0-0.040	CuCrZr		● ● ● ●
AM6CT12	Contact Tip	M12*40.5	1.2-0.045	CuCrZr	Fe, Fe-FC/MC	● ● ● ●
AM6CT14	Contact Tip	M12*40.5	1.4-0.055	CuCrZr	SS,SS-FC/MC	● ● ● ●
AM6CT16	Contact Tip	M12*40.5	1.6-0.063	CuCrZr	upto 1.2mm	● ● ● ●
AM6CT20	Contact Tip	M12*40.5	2.0-0.080	CuCrZr		● ● ● ●

<b>Standard Series</b> - Recommended for Fe, Fe-MC/FC Set-up						
AM6WCT09	Contact Tip	M10*35.5	0.9-0.035	CuCrZr		● ● ● ●
AM6WCT10	Contact Tip	M10*35.5	1.0-0.040	CuCrZr		● ● ● ●
AM6WCT12	Contact Tip	M10*35.5	1.2-0.045	CuCrZr	Fe, Fe-FC/MC	● ● ● ●
AM6WCT14	Contact Tip	M10*35.5	1.4-0.055	CuCrZr	SS,SS-FC/MC	● ● ● ●
AM6WCT16	Contact Tip	M10*35.5	1.6-0.063	CuCrZr	upto 1.2mm	● ● ● ●
AM6WCT20	Contact Tip	M10*35.5	2.0-0.080	CuCrZr		● ● ● ●

<b>A Series</b> - Recommended for Aluminium and SS Set-up						
AM5CT10A	Contact Tip	M8*29.5	1.0-0.040	CuCrZr	Aluminium	● ● ● ●
AM5CT12A	Contact Tip	M8*29.5	1.2-0.045	CuCrZr	SS, SS-FC/MC	● ● ● ●
AM2CT10A	Contact Tip	M8*29.5	1.0-0.040	Copper	upto 1.6mm	● ● ● ●
AM2CT12A	Contact Tip	M8*29.5	1.2-0.045	Copper		● ● ● ●

● Standard wear part range ● Torch package standard wear part set-up

## Contact Tips



Part No.	Description	Size mm	Wire Size mm-Inch	Material	Wire Type	M3 M4 M5 M6
<b>A Series</b> - Recommended for Aluminium and SS Set-up						
AM6CT10A	Contact Tip	M12*40.5	1.0-0.040	CuCrZr	Aluminium SS, SS-FC/MC upto 1.6mm	● ● ● ●
AM6CT12A	Contact Tip	M12*40.5	1.2-0.045	CuCrZr		● ● ● ●
AM6CT16A	Contact Tip	M12*40.5	1.6-0.063	CuCrZr		● ● ● ●
AM6CT20A	Contact Tip	M12*40.5	1.0-0.040	CuCrZr		● ● ● ●
AMC6CT10A	Contact Tip	M12*40.5	1.2-0.045	Copper		● ● ● ●
AMC6CT12A	Contact Tip	M12*40.5	2.0-0.080	Copper		● ● ● ●

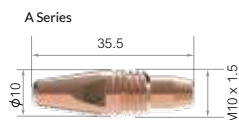

Part No.	Description	Size mm	Wire Size mm-Inch	Material	Wire Type	M3 M4 M5 M6
<b>A Series</b> - Recommended for Aluminium and SS Set-up						
AM6WCT10A	Contact Tip	M10*35.5	1.0-0.040	CuCrZr	Aluminium SS, SS-FC/MC 1.6mm	● ● ● ●
AM6WCT12A	Contact Tip	M10*35.5	1.2-0.045	CuCrZr		● ● ● ●
AM6WCT16A	Contact Tip	M10*35.5	1.6-0.063	CuCrZr		● ● ● ●
AMC6WCT10A	Contact Tip	M10*35.5	1.0-0.040	Copper		● ● ● ●
AMC6WCT12A	Contact Tip	M10*35.5	1.2-0.045	Copper		● ● ● ●

### Contact Tip Performance Tests

How many contact tips do you use per day, per week, per year?

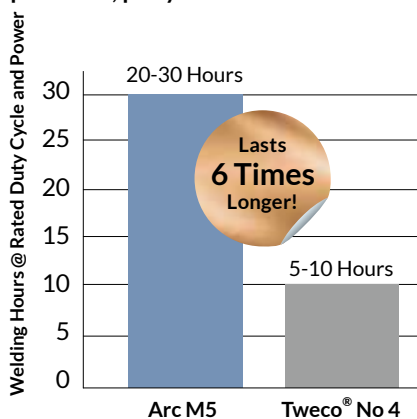

® All trademarks are the property of their respective owners and usage is for cross reference only

● Standard wear part range ● Torch package standard wear part set-up

## Tip Adaptors

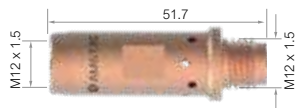
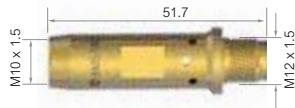
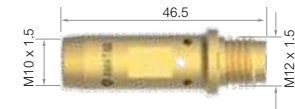

Part No.	Description	Length	Material	Transfer	Amps / Pulse	M3	M4	M5	M6
Recommended for high amperages, high duty and pulse welding. Tips run cooler									
AM3TAC	Tip Adaptor High Performance	44.2mm	CuCrZr		High Current Pulse	●	●	●	●
AM3TAB	Tip Adaptor	44.2mm	Brass		Low Current Pulse	●	●	●	●
AM4TAC	Tip Adaptor High Performance	46.5mm	CuCrZr		High Current Pulse	●	●	●	●
AM4TAB	Tip Adaptor	46.5mm	Brass		Low Current Pulse	●	●	●	●
Recommended for high amperages, high duty and pulse welding. Tips run cooler									
AM5TAC	Tip Adaptor High Performance	51.7mm	CuCrZr		High Current Pulse	●	●	●	●
AM5TAB	Tip Adaptor	51.7mm	Brass		Low Current Pulse	●	●	●	●
AM6TAC	Tip Adaptor High Performance	51.7mm	CuCrZr		High Current Pulse	●	●	●	●
AM6TAB	Tip Adaptor	51.7mm	Brass		Low Current Pulse	●	●	●	●

## Tip Adaptor Performance Tests

How many Tip Adaptors do you use per day, per week, per year?

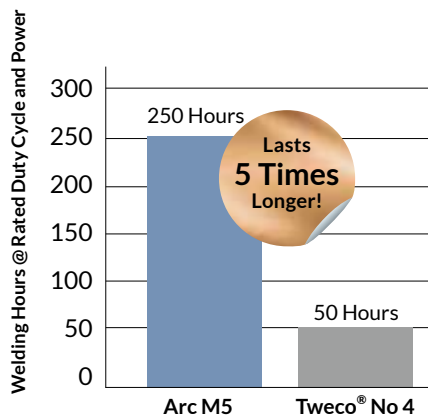

® All trademarks are the property of their respective owners and usage is for cross reference only

● Standard wear part range ● Torch package standard wear part set-up

### Liners

### Filler Metal

**Steel Liner** Recommended for: Fe, Fe-MC/FC. Light and medium duty applications

Part No.	Description	Nipple	Wire Size mm	M3 M4 M5 M6
AM1535-30	Steel Liner x 3mt	Moulded Nipple	0.6-0.9	● ● ● ●
AM1535-40	Steel Liner x 4mt	Moulded Nipple	0.6-0.9	● ● ● ●
AM1535-50	Steel Liner x 5mt	Moulded Nipple	0.6-0.9	● ● ● ●



AM2524-30	Steel Liner x 3mt	Moulded Nipple	1.0-1.2	● ● ● ●
AM2524-40	Steel Liner x 4mt	Moulded Nipple	1.0-1.2	● ● ● ●
AM2524-50	Steel Liner x 5mt	Moulded Nipple	1.0-1.2	● ● ● ●



### Filler Metal Fe, Fe-MC/FC

**Steel Liner** Recommended for: Light and medium duty applications

Part No.	Description	Contact Tip	Wire Size mm	M3 M4 M5 M6
AM6SL-1012-30	Steel Liner x 3mt	Standard Series	1.0-1.2	● ● ● ●
AM6SL-1012-40	Steel Liner x 4mt	Standard Series	1.0-1.2	● ● ● ●
AM6SL-1012-50	Steel Liner x 5mt	Standard Series	1.0-1.2	● ● ● ●



AM6SL-16-30	Steel Liner x 3mt	Standard Series	1.6	● ● ● ●
AM6SL-16-40	Steel Liner x 4mt	Standard Series	1.6	● ● ● ●
AM6SL-16-50	Steel Liner x 5mt	Standard Series	1.6	● ● ● ●



AM6SL-20-30	Steel Liner x 3mt	Standard Series	2.0	● ● ● ●
AM6SL-20-40	Steel Liner x 4mt	Standard Series	2.0	● ● ● ●
AM6SL-20-50	Steel Liner x 5mt	Standard Series	2.0	● ● ● ●



● Standard wear part range ● Torch package standard wear part set-up

**Liners**

**Filler Metal** SS, SS-MC/FC

**Stainless Steel Liner** Recommended for: Heavy Duty Fe. High amperages and heavy deposition welding

Part No.	Description	Contact Tip	Wire Size mm	M3 M4 M5 M6
AM6SSTL-1012-30	Stainless Steel Liner x 3mt	Standard Series	1.0-1.2	● ● ● ●
AM6SSTL-1012-40	Stainless Steel Liner x 4mt	Standard Series	1.0-1.2	● ● ● ●
AM6SSTL-1012-50	Stainless Steel Liner x 5mt	Standard Series	1.0-1.2	● ● ● ●



AM6SSTL-16-30	Stainless Steel Liner x 3mt	A Series	1.6	● ● ● ●
AM6SSTL-16-40	Stainless Steel Liner x 4mt	A Series	1.6	● ● ● ●
AM6SSTL-16-50	Stainless Steel Liner x 5mt	A Series	1.6	● ● ● ●



**Filler Metal** AlMg

**Al - Combi Liner** Recommended for: Air-Cooled torches, Can be used for SS-MC/FC wires

Part No.	Description	Contact Tip	Wire Size mm	M3 M4 M5 M6
AM1564-30	Combi-Liner x 3mt	A Series	0.8-1.2	● ● ● ●
AM1564-40	Combi-Liner x 4mt	A Series	0.8-1.2	● ● ● ●
AM1564-50	Combi-Liner x 5mt	A Series	0.8-1.2	● ● ● ●



**Al - Combi Liner** Recommended for: Liquid-Cooled torches and frequent /repetitive arc starts

AM6CL-1012-30	Combi-Liner x 3mt	A Series	1.0-1.2	● ● ● ●
AM6CL-1012-40	Combi-Liner x 4mt	A Series	1.0-1.2	● ● ● ●
AM6CL-1012-50	Combi-Liner x 5mt	A Series	1.0-1.2	● ● ● ●



● Standard wear part range ● Torch package standard wear part set-up



# WEAR PARTS

## High Performance Series



MAKE WORK  
LIFE EASIER

### Liners

### Filler Metal <sub>AlMg</sub>

**Al - Combi Liner** Recommended for: Liquid-cooled torches and frequent /repetitive arc starts

Part No.	Description	Contact Tip	Wire Size mm	M3 M4 M5 M6
AM6CL-1620-30	Combi-Liner x 3mt	A Series	1.6	● ● ● ●
AM6CL-1620-40	Combi-Liner x 4mt	A Series	1.6	● ● ● ●
AM6CL-1620-50	Combi-Liner x 5mt	A Series	1.6	● ● ● ●



AMOSW_LINER-T	Soft Wire / Combi-Liner Set-up Kit	● ● ● ●
---------------	------------------------------------	---------

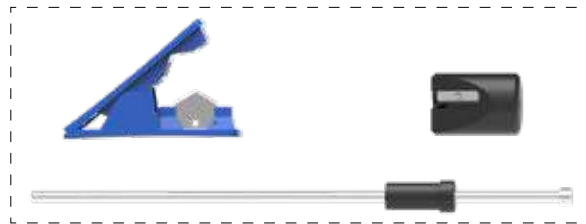

● Standard wear part range ● Torch package standard wear part set-up

The design, manufacturing and quality systems of Arc Torchology are certified by **BVQI** in accordance with EN/ISO 9001:2015

ARCTORCHHOLOGY.COM



Arc T

**SAY HELLO**

TO OUR VISION OF THE FUTURE

ARC M SERIES

Make Work Life Easier

MPA001 / 2024.7



MAKE WORK  
LIFE EASIER